

# HP Pavilion HDX Entertainment Notebook PC Maintenance and Service Guide



© Copyright 2007 Hewlett-Packard  
Development Company, L.P.

Bluetooth is a trademark owned by its proprietor and used by Hewlett-Packard Company under license. Intel and Core are trademarks or registered trademarks of Intel Corporation or its subsidiaries in the United States and other countries. Microsoft, Windows, and Windows Vista are either trademarks or registered trademarks of Microsoft Corporation in the United States and/or other countries. SD Logo is a trademark of its proprietor.

The information contained herein is subject to change without notice. The only warranties for HP products and services are set forth in the express warranty statements accompanying such products and services. Nothing herein should be construed as constituting an additional warranty. HP shall not be liable for technical or editorial errors or omissions contained herein.

First Edition: July 2007

Document Part Number: 443051-001

## Safety warning notice

---

- ⚠ **WARNING!** To reduce the possibility of heat-related injuries or of overheating the computer, do not place the computer directly on your lap or obstruct the computer air vents. Use the computer only on a hard, flat surface. Do not allow another hard surface, such as an adjoining optional printer, or a soft surface, such as pillows or rugs or clothing, to block airflow. Also, do not allow the AC adapter to contact the skin or a soft surface, such as pillows or rugs or clothing, during operation. The computer and the AC adapter comply with the user-accessible surface temperature limits defined by the International Standard for Safety of Information Technology Equipment (IEC 60950).
-



---

# Table of contents

## 1 Product description

## 2 External component identification

Top components .....	6
Display and top components .....	6
Top-left buttons and lights .....	7
Top-right buttons, lights, and fingerprint reader .....	9
TouchPad .....	10
Keys .....	11
Front components .....	12
Rear components .....	13
Rear left-side components .....	13
Rear right-side components .....	14
Right-side components .....	15
Left-side components .....	16
Bottom components .....	17

## 3 Illustrated parts catalog

Serial number location .....	18
Computer major components .....	19
Display assembly components .....	23
Plastics Kit .....	24
Mass storage devices .....	25
Miscellaneous parts .....	26
Sequential part number listing .....	27

## 4 Removal and replacement procedures

Preliminary replacement requirements .....	31
Tools required .....	31
Service considerations .....	31
Plastic parts .....	31
Cables and connectors .....	32
Drive handling .....	32
Grounding guidelines .....	33
Electrostatic discharge damage .....	33
Packaging and transporting guidelines .....	34
Workstation guidelines .....	34
Equipment guidelines .....	35

Unknown user password .....	36
Component replacement procedures .....	37
Serial number .....	37
Battery .....	38
Computer feet .....	39
Display assembly internal components .....	40
Hard drive .....	45
WLAN module .....	47
TV tuner module .....	49
Memory module .....	50
Optical drive .....	52
Keyboard .....	54
Hinge cover .....	56
Rear cover .....	57
Top cover .....	59
Fingerprint reader board .....	61
TouchPad on/off board .....	62
Display assembly .....	64
Audio/infrared board .....	67
Bluetooth module .....	68
Front USB board .....	69
Power connector LED board .....	70
Rear USB board .....	71
Subwoofer .....	72
Video connector board .....	73
Processor fan .....	75
System board .....	76
Audio connector board .....	80
RTC battery .....	81
Processor heat sink .....	83
Processor .....	85
Video board heat sink .....	87
Video board fan .....	89
Video board .....	90

## 5 Computer Setup

Starting Computer Setup .....	92
Using Computer Setup .....	93
Changing the language of Computer Setup .....	93
Navigating and selecting in Computer Setup .....	93
Displaying system information .....	93
Restoring default settings in Computer Setup .....	94
Closing Computer Setup .....	94
Computer Setup menus .....	95
File menu .....	95
Security menu .....	96
Diagnostics menu .....	96
System Configuration menu .....	97

## 6 Specifications

Computer specifications .....	98
20.1-inch, WUXGA display specifications .....	99
20.1-inch WSXGA+ display specifications .....	100
Hard drive specifications .....	101
DVD±RW and CD-RW Super Multi Double-Layer Combo Drive specifications .....	102
System DMA specifications .....	103
System interrupt specifications .....	104
System I/O address specifications .....	105
System memory map specifications .....	107

## 7 Screw listing

Phillips PM2.5×5.0 screw .....	108
Black Phillips PM2.0×5.0 captive screw .....	113
Phillips PM2.5×12.0 captive screw .....	114
Phillips PM3.0×4.0 screw .....	115
Phillips PM2.5×8.0 screw .....	116
Phillips PM2.0×3.0 screw .....	118
Phillips PM3.0×8.0 screw .....	119
Phillips PM2.5×4.0 screw .....	121
Phillips PM3.0×12.0 screw .....	122
Phillips 2.5×3.0 broad-head screw .....	123
Phillips PM2.5×11.0 screw .....	124
Silver Phillips PM2.0×4.0 screw .....	125
Slotted SM1.5×9.0 shoulder screw .....	127
Phillips PM2.5×13.0 captive screw .....	128
Silver Phillips PM2.0×5.0 captive screw .....	129
Phillips PM2.5×8.0 captive screw .....	130
Black Phillips PM2.0×4.0 screw .....	131

## 8 Backup and Recovery

Recovering system information .....	132
Creating recovery discs .....	132
Backing up your information .....	133
When to back up .....	133
Back up suggestions .....	134
Using system restore points .....	134
When to create restore points .....	134
Create a system restore point .....	134
Restore to a previous date and time .....	136
Performing a recovery .....	137
Recovering from the recovery discs .....	137
Recovering from the partition on the hard drive .....	137

## 9 Connector pin assignments

Audio-out (headphone) .....	138
Audio-in (microphone) .....	138
External monitor .....	139
RJ-45 (network) .....	140

Universal Serial Bus .....	141
<b>10 Power cord set requirements</b>	
Requirements for all countries or regions .....	142
Requirements for specific countries or regions .....	143
<b>11 Recycling</b>	
Battery .....	144
Display .....	144
<b>Index .....</b>	<b>150</b>



# 1 Product description

Category	Description
<b>Product Name</b>	HP Pavilion HDX Entertainment Notebook PC
<b>Processors</b>	<b>Intel® Core™ 2 Extreme processors (4-MB L2 cache, 800-MHz front side bus (FSB), 44-W):</b> X7900 2.8-GHz processor X7800 2.6-GHz processor <b>Intel® Core™ Duo processors (4-MB L2 cache, 800-MHz FSB, 35-W):</b> T7700 2.4-GHz processor T7500 2.2-GHz processor T7300 2.0-GHz processor T7100 1.8-GHz processor System design supports up to 55-W requirement
<b>Chipset</b>	Northbridge: Intel PM965 Southbridge: ICH8m
<b>Graphics</b>	ATI Discrete PCI Express x 16 Graphics via MXM
<b>Panels</b>	20.1-inch WSXGA UltraBrightView (1680 × 1050), ~300 nits typical brightness
<b>Memory</b>	2 SODIMM slots Customer-accessible/upgradable PC2-5300, 667-MHz, DDR2 Dual-channel support Supports up to 4096 MB of system memory <ul style="list-style-type: none"><li>• 4096-MB total system memory (2048 MB × 2)</li><li>• 2048-MB total system memory (1024 MB × 2)</li><li>• 1024-MB total system memory (512 MB × 2)</li></ul>
<b>Hard drives</b>	Supports all Serial ATA (SATA) 9.5-mm, 2.5-inch hard drives RAID software support not required for second hard drive

Category	Description
	Dual hard drive configurations: <ul style="list-style-type: none"> <li>• 400-GB, 4200-rpm (200 GB × 2)</li> <li>• 320-GB, 5400-rpm (160 GB × 2)</li> <li>• 280-GB, 5400-rpm (160 GB + 120 GB)</li> <li>• 240-GB, 5400-rpm (120 GB + 120 MB)</li> <li>• 200-GB, 7200-rpm (100 GB × 2)</li> </ul>
<b>Optical drives</b>	12.7-mm tray load Parallel ATA Fixed (1 screw for removal) Support for the following optical drives: <ul style="list-style-type: none"> <li>• DVD±RW and CD-RW Super Multi Double-Layer Combo Drive with LightScribe</li> <li>• HD-DVD Drive (with read-only function)</li> </ul>
<b>Camera</b>	Low-light VGA camera Tilt: +/- 15 degrees, with activity LED 640 × 480 by 30 frames per second
<b>Diskette drive</b>	Supports external USB drive only
<b>Audio</b>	HD audio: SigmaTel STAC9271D5TAyy 10-channel, simultaneous Voice over IP (VoIP) output (V.7.1), with 95-dB signal-to-noise ratio (SNR) Dolby home theater support 12-band parametric equalizer (disabled when external connections are made) Dynamic processing for tunable compression/limiter function
	<b>Speakers requirements:</b>
	4 speakers (40 mm × 20 mm × 10 mm dimensions)
	2 speaker enclosures on the display panel, each with a 30-cc chamber
	40-mm subwoofer located in base enclosure with 110-cc chamber, mechanically isolated from the computer with soft elastomeric grommets and foam
	V. 7.1 analog out and supported ports
	Supports Microsoft Premium requirements
	Pavilion-branded Altec Lansing speakers
	2 omnidirectional microphones
<b>Modem</b>	No integrated modem
<b>Ethernet</b>	Intel 10/100/1000 Gigabit Ethernet network interface card (NIC)
<b>Wireless</b>	Integrated wireless local area network (WLAN) options by way of wireless module:

Category	Description
	Intel PRO wireless 4965 a/b/g with 2 WLAN antennae built into the display assembly + Bluetooth®
	Intel PRO wireless 4965 a/b/g/n with 3 WLAN antennae built into the display assembly + Bluetooth
	Intel PRO wireless 3945 a/b/g with 2 WLAN antennae built into the display assembly + Bluetooth
<b>Integrated TV tuner options</b>	Integrated NTSC/ATSC hybrid TV tuner (in Canada and the United States)
	Integrated analog/DVB-T TV tuner (in the rest of the world)
	PAL to F-jack and infrared emitter with cable, included with TV tuner option
	TV tuner antennas for both DVB-T and ATSC/NTSC
<b>External media card</b>	One ExpressCard 54 slot, supports hybrid analog+ATSC and DVB-T TV tuner
	Digital Media Slot: supports SD, MMC, SD I/O, MS, MSP, xD-Picture Card; with adapter, supports mini versions of SD, MMC, and MS Duo (adapter is not included)
<b>Ports</b>	<b>Video ports:</b>
	VGA (Dsub 15-pin) supporting 1920 × 1200 external resolution @ 75 Hz, hot plug/unplug, and auto-detect for correct output to wide-aspect video (disabled when connected to the HP xb3000 Notebook Expansion Base and HP Notebook QuickDock)
	High-definition multimedia interface (HDMI) V.1.2 supporting 1080p with High-bandwidth Digital Content Protection (HDCP) key
	<b>Audio ports:</b>
	Analog audio-out V.7.1
	Audio-in (stereo microphone)
	Audio-out (stereo headphone, 2 ports)
	Center low-frequency effect (LFE) output
	Front, rear, and side speaker outputs
	Consumer infrared
	<b>TV tuner ports:</b>
	Stereo audio input
	RF input using PAL jack
	S-Video capture input
	Infrared emitter jack
	<b>Other ports:</b>
	AC power through 180-W Multipin AC adapter plug (Smart AC adapter)
	Consumer infrared
	eSATA
	IEEE 1394a
	RJ-45 (Ethernet, includes link and activity lights)

Category	Description
	S-Video-out (including composite video support) via docking only
	USB (4)
<b>Remote control</b>	The remote control is docked into the keyboard deck. The remote control can be ejected by pressing the remote control eject button. The remote control can also be locked onto the computer.
	Software codes for all keys follow Microsoft® Media Center requirements.
	The remote control battery is customer-accessible/upgradable.
	Remote control weight: <ul style="list-style-type: none"> <li>• Without batteries: 41.5 to 46.5 grams</li> <li>• With batteries: 45.0 to 50.0 grams</li> </ul>
	Remote control buttons: <ul style="list-style-type: none"> <li>• MS Start (MCE green)</li> <li>• Numeric keypad (0 - 9)</li> <li>• Clear</li> <li>• Enter</li> <li>• Channel up/down</li> <li>• Volume up/down</li> <li>• Fast forward</li> <li>• Reverse</li> <li>• Play/pause</li> <li>• Previous/next track</li> <li>• OK</li> <li>• Back</li> <li>• Mute</li> <li>• Guide</li> <li>• DVD player</li> <li>• TV (in the United States)/Teletext (in Europe, the Middle East, and Africa)</li> <li>• QuickPlay launch</li> <li>• Record</li> <li>• Information</li> <li>• Power</li> <li>• Music (in the United States)/R (in Europe, the Middle East, and Africa)</li> <li>• Photos (in the United States)/G (in Europe, the Middle East, and Africa)</li> </ul>

Category	Description
	<ul style="list-style-type: none"> <li>• Video (in the United States)/Y (in Europe, the Middle East, and Africa)</li> <li>• Zoom (in the United States)/B (in Europe, the Middle East, and Africa)</li> </ul>
<b>Docking</b>	Expansion port 3 supports the HP xb3000 Notebook Expansion Base and HP Notebook QuickDock (does not support power via dock)
<b>Keyboard/pointing devices</b>	14.39-inch full-size keyboard with separate numeric keypad
	Touchpad supports 2-way scrolling
	Taps enabled as default
<b>Power requirements</b>	9-cell 2.55-Ah, 83-Wh Li-ion battery
	180-W non-PFC AC adapter with localized cable plug support (multiwire plug with ground pin, supports 2-pin DC connector)
<b>Security</b>	Security cable slot
	Fingerprint reader with VeriSoft software support
<b>Operating system</b>	<b>Preinstalled:</b>
	Windows Vista® Ultimate (64-bit)
	Windows Vista Premium (32-bit)
<b>Serviceability</b>	<b>End-user replaceable parts:</b>
	AC adapter
	Battery (system)
	Hard drives (2)
	Memory module
	Optical drive
	WLAN module

## 2 External component identification

### Top components

#### Display and top components



Item	Component	Description
(1)	Speakers (4)	Produce sound.
(2)	Internal microphones (2) (select models only)	Record sound. <b>NOTE:</b> If there is a microphone icon next to each microphone opening, the computer has internal microphones.
(3)	HP Webcam light	On: The integrated camera is in use.
(4)	HP Webcam	Records video and captures still photographs.

Item	Component	Description
(5)	HP Webcam rotator	Tilts the camera vertically.
(6)	Internal display switch	Turns off the display if the display is closed while the computer is on.

## Top-left buttons and lights



Item	Component	Description
(1)	Power button*	<ul style="list-style-type: none"> <li>When the computer is off, press the button to turn on the computer.</li> <li>When the computer is on, press the button to initiate Sleep.</li> <li>When the computer is in the Sleep state, press the button briefly to exit Sleep.</li> <li>When the computer is in Hibernation, press the button briefly to exit Hibernation.</li> </ul> <p>If the computer has stopped responding and Windows® shutdown procedures are ineffective, press and hold the power button for at least 5 seconds to turn off the computer.</p> <p>To learn more about your power settings, select <b>Start &gt; Control Panel &gt; System and Maintenance &gt; Power Options</b>.</p>
(2)	Power light	<ul style="list-style-type: none"> <li>On: The computer is on.</li> <li>Blinking: The computer is in the Sleep state.</li> <li>Off: The computer is off or in Hibernation.</li> </ul>
(3)	Media button	<ul style="list-style-type: none"> <li>Opens the QuickPlay program (for models with QuickPlay preinstalled).</li> <li>Opens the DVDPlay program (for models with DVDPlay preinstalled).</li> </ul>

Item	Component	Description
		<b>NOTE:</b> If the computer has been set up to require a logon password, you may be asked to log on to Windows. QuickPlay or DVDPlay opens after you log on. Refer to the QuickPlay or DVDPlay software Help for more information.
(4)	DVD button	Opens the DVD playback feature of the QuickPlay program.  <b>NOTE:</b> If the computer has been set up to require a logon password, you may be asked to log on to Windows. QuickPlay opens after you log on. Refer to the QuickPlay software Help for more information.
(5)	TV play button	Opens the TV module within the QuickPlay program.
(6)	Previous/rewind button	<ul style="list-style-type: none"> <li>Plays the previous track or chapter when the button is pressed once.</li> <li>Rewinds media when the button is pressed simultaneously with the <b>fn</b> key.</li> </ul>
(7)	Stop button	Stops playback.
(8)	Play/pause button	Plays or pauses media.
(9)	Next/fast forward button	<ul style="list-style-type: none"> <li>Plays the next track or chapter when the button is pressed once.</li> <li>Fast forwards media when the button is pressed simultaneously with the <b>fn</b> key.</li> </ul>
(10)	Theater mode button	Dims the lights on the computer.
(11)	Remote control button	Ejects the remote control.
(12)	Caps lock light	On: Caps lock is on.
*This table describes factory settings. For information about changing factory settings, refer to the user guides located in Help and Support.		



## Top-right buttons, lights, and fingerprint reader



Item	Component	Function
(1)	Fingerprint reader	Allows a fingerprint logon to Windows, instead of a password logon.
(2)	Wireless button	Turns the wireless feature on or off, but does not create a wireless connection.  <b>NOTE:</b> To establish a wireless connection, a wireless network must already be set up.
(3)	Wireless light	<ul style="list-style-type: none"> <li>Blue: All integrated wireless devices, such as WLAN devices and/or Bluetooth® devices, are turned on.</li> <li>Amber: All integrated wireless devices are turned off.</li> </ul>
(4)	Volume mute button	Mutes and restores speaker sound.
(5)	Volume mute light	<ul style="list-style-type: none"> <li>Blue: Computer sound is turned on.</li> <li>Amber: Computer sound is turned off.</li> </ul>
(6)	Volume down light	Blinking: The volume scroll zone is being used to decrease speaker volume.
(7)	Volume scroll zone	Adjusts speaker volume. Slide your finger to the left to decrease volume and to the right to increase volume. You can also tap the minus sign on the scroll zone to decrease volume, or tap the plus sign on the scroll zone to increase volume.
(8)	Volume up light	Blinking: The volume scroll zone is being used to increase speaker volume.
(9)	Treble or bass volume down light (select models only)	Blinking: The volume scroll zone is being used to decrease treble or bass volume.
(10)	Treble or bass volume scroll zone (select models only)	Adjusts treble or bass volume. Slide your finger to the left to decrease volume and to the right to increase volume. You can also tap the minus sign on the scroll zone to decrease volume, or tap the plus sign on the scroll zone to increase volume.
(11)	Treble or bass volume up light (select models only)	Blinking: The volume scroll zone is being used to increase treble or bass volume.
(12)	Optical drive button	Releases the media tray.
(13)	Optical drive light	Blinking: The optical drive is being accessed.

Item	Component	Function
(14)	Treble light (select models only)	On: The treble volume function is on.
(15)	Bass light (select models only)	On: The bass volume function is on.
(16)	Treble/bass button (select models only)	Alternates between treble and bass volume controls.
(17)	Num lock light	On: Num lock is on or the embedded numeric keypad is enabled.

## TouchPad



Item	Component	Function
(1)	TouchPad light	<ul style="list-style-type: none"> <li>• Blue: TouchPad is enabled.</li> <li>• Amber: TouchPad is disabled.</li> </ul>
(2)	TouchPad*	Moves the pointer and selects or activates items on the screen.
(3)	Left TouchPad button*	Functions like the left button on an external mouse.
(4)	TouchPad on/off button	Enables/disables the TouchPad.
(5)	TouchPad scroll zone*	Scrolls up or down.
(6)	Right TouchPad button*	Functions like the right button on an external mouse.

\*This table describes factory settings. View or change pointing device preferences by selecting **Start > Control Panel > Hardware and Sound > Mouse**.

# Keys

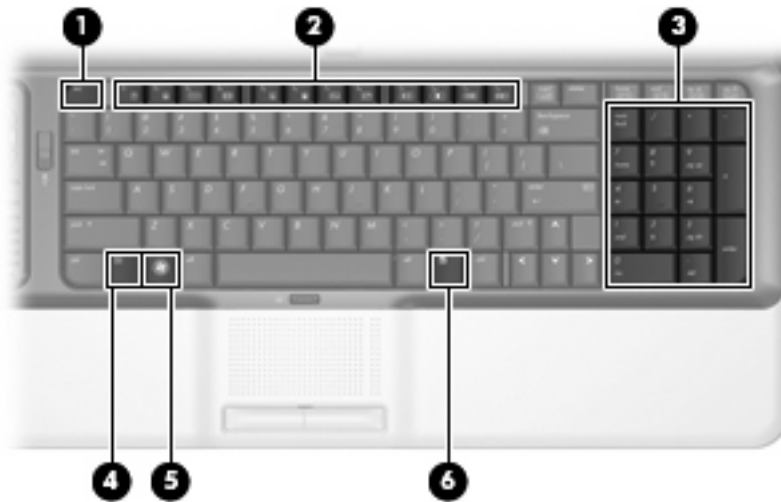

Item	Component	Description
(1)	esc key	Displays system information when pressed in combination with the <b>fn</b> key.
(2)	Function keys	Execute frequently used system functions when pressed in combination with the <b>fn</b> key.
(3)	Integrated numeric keypad keys	Can be used like the keys on an external numeric keypad.
(4)	fn key	Executes frequently used system functions when pressed in combination with a function key or the <b>fn</b> key.
(5)	Windows logo key	Displays the Windows Start menu.
(6)	Windows applications key	Displays a shortcut menu for items beneath the pointer.

## Front components



Item	Component	Function
(1)	Power light	<ul style="list-style-type: none"> <li>On: The computer is on.</li> <li>Blinking: The computer is in the Sleep state.</li> <li>Off: The computer is off or in Hibernation.</li> </ul>
(2)	Battery light	<ul style="list-style-type: none"> <li>On: A battery is charging.</li> <li>Blinking: A battery that is the only available power source has reached a low battery level or a critical battery level.</li> <li>Off: If the computer is plugged into an external power source, the light is turned off when all batteries in the computer are fully charged. If the computer is not plugged into an external power source, the light stays off until the battery reaches a low battery level.</li> </ul>
(3)	Drive light	Blinking: The hard drive or optical drive is being accessed.
(4)	Consumer infrared lens	Receives a signal from a remote control device, such as the HP Remote Control.
(5)	Audio-in (microphone) jack	Connects an optional computer headset microphone, stereo array microphone, or monaural microphone.
(6)	Audio-out (headphone) jacks (2)	Produce sound when connected to optional powered stereo speakers, headphones, ear buds, a headset, or television audio.

# Rear components

## Rear left-side components

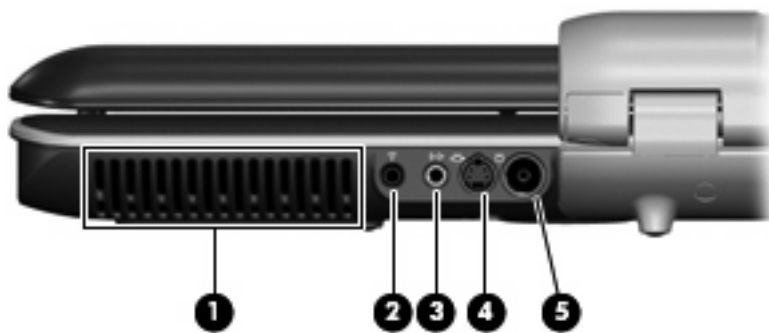

Item	Component	Description
(1)	Vent	Enables airflow to cool internal components. <b>NOTE:</b> The computer fan starts up automatically to cool internal components and prevent overheating. It is normal for the internal fan to cycle on and off during routine operation.
(2)	Infrared (IR) emitter jack	Connects the computer to your cable or satellite set-top box.
(3)	TV audio line-in jack	Connects a cable or satellite set-top box to the TV tuner for high-quality audio.
(4)	S-Video-in jack	Connects a cable or satellite set-top box to the TV tuner for high-quality video.
(5)	RF coaxial cable jack	Connects a coaxial cable or TV antenna. <b>NOTE:</b> The computer is shipped with an RF coaxial cable adapter. Depending on your computer model, the adapter may be required for proper setup.

## Rear right-side components

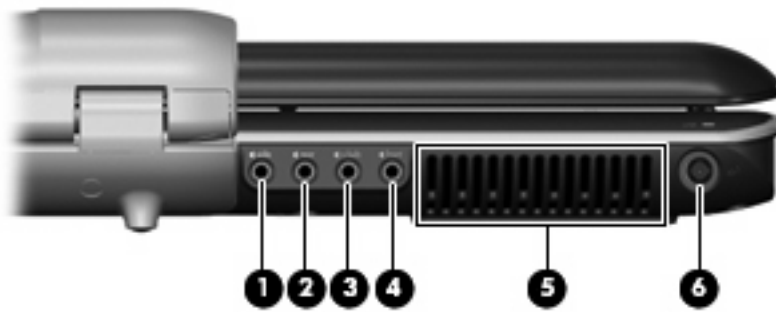

Item	Component	Description
(1)	Left- and right-side analog channel output jack	Connects optional audio speakers for left- and right-side audio output.
(2)	Rear left- and right-side analog channel output jack	Connects optional audio speakers for rear left- and right-side audio output.
(3)	Center channel and subwoofer analog channel output jack	Connects an optional audio speaker for center channel and subwoofer audio output.
(4)	Front left- and right-side analog channel output jack	Connects optional audio speakers for front left- and right-side audio output.
(5)	Vent	Enables airflow to cool internal components. <b>NOTE:</b> The computer fan starts up automatically to cool internal components and prevent overheating. It is normal for the internal fan to cycle on and off during routine operation.
(6)	Power connector	Connects an AC adapter.

## Right-side components

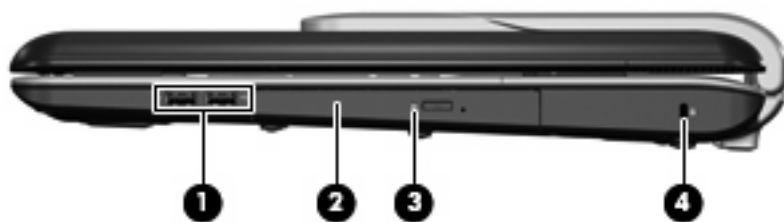

Item	Component	Function
(1)	USB ports (2)	Connect optional USB devices.
(2)	Optical drive	Reads optical discs, and, on select models, also writes to optical discs.
(3)	Optical drive light	Blinking: The optical drive is being accessed.
(4)	Security cable slot	Attaches an optional security cable to the computer.

**NOTE:** The security cable is designed to act as a deterrent, but it may not prevent the computer from being mishandled or stolen.

## Left-side components



Item	Component	Function
(1)	USB ports (2)	Connect optional USB devices.
(2)	RJ-45 (network) jack	Connects a network cable.
(3)	Expansion port 3	Connects the computer to an optional docking device or expansion product.  <b>NOTE:</b> The computer has only one expansion port. The term <i>expansion port 3</i> describes the type of expansion port.
(4)	External monitor port	Connects an external VGA monitor or projector.
(5)	HDMI port (select models only)	Connects an optional video or audio device, such as a high-definition television, or any compatible digital or audio device.
(6)	eSATA port	Connects high-performance eSATA components, such as an eSATA external hard drive.
(7)	1394 port	Connects an optional IEEE 1394 or 1394a device, such as a camcorder.
(8)	Digital Media Slot light	On: A digital card is being accessed.
(9)	Digital Media Slot (select models only)	Supports the following optional digital card formats: <ul style="list-style-type: none"> <li>• Memory Stick (MS)</li> <li>• Memory Stick Pro (MSP)</li> <li>• MultiMediaCard (MMC)</li> <li>• Secure Digital Input/Output (SD I/O)</li> <li>• Secure Digital (SD) Memory Card</li> <li>• xD-Picture Card (XD)</li> <li>• xD-Picture Card (XD) Type H</li> <li>• xD-Picture Card (XD) Type M</li> </ul>
(10)	ExpressCard slot	Supports optional ExpressCard cards.



# Bottom components

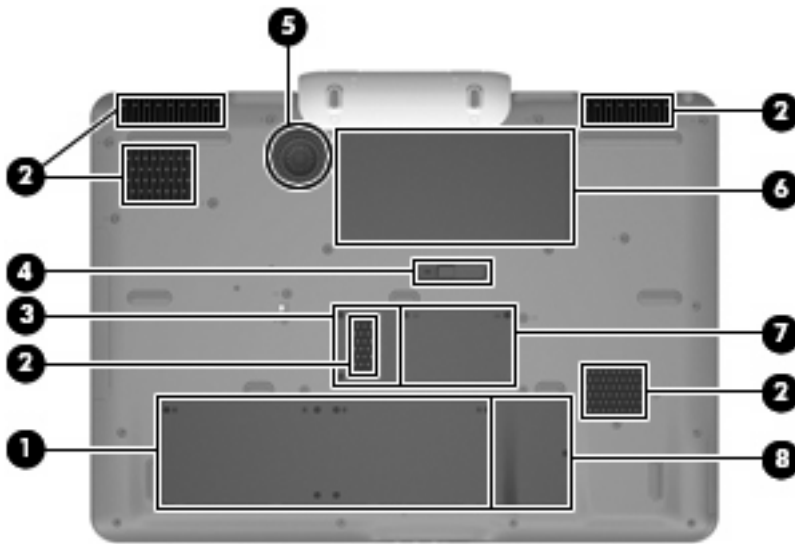

Item	Component	Function
(1)	Hard drive bay	Holds the hard drives.  <b>NOTE:</b> Depending on the computer model, the computer may have 1 or 2 hard drives.
(2)	Vents (5)	Enable airflow to cool internal components.  <b>NOTE:</b> The computer fans start up automatically to cool internal components and prevent overheating. It is normal for the internal fans to cycle on and off during routine operation.
(3)	TV tuner module compartment	Contains the TV tuner slot.
(4)	Battery release latch	Releases the battery from the battery bay.
(5)	Subwoofer	Contains the subwoofer speaker.
(6)	Battery bay	Holds the battery.
(7)	Memory module compartment	Contains the memory module slots.
(8)	Mini Card compartment (select models only)	Holds a WLAN device.  <b>NOTE:</b> To prevent an unresponsive system and the display of a warning message, replace with only a Mini Card device authorized for use in the computer by the governmental agency that regulates wireless devices in your country. If you replace the device and then receive a warning message, remove the device to restore computer functionality. Then contact technical support by selecting <b>Start &gt; Help and Support &gt; Contact support</b> .

---

## 3 Illustrated parts catalog

### Serial number location

When ordering parts or requesting information, provide the computer serial number and model number located on the bottom of the computer.

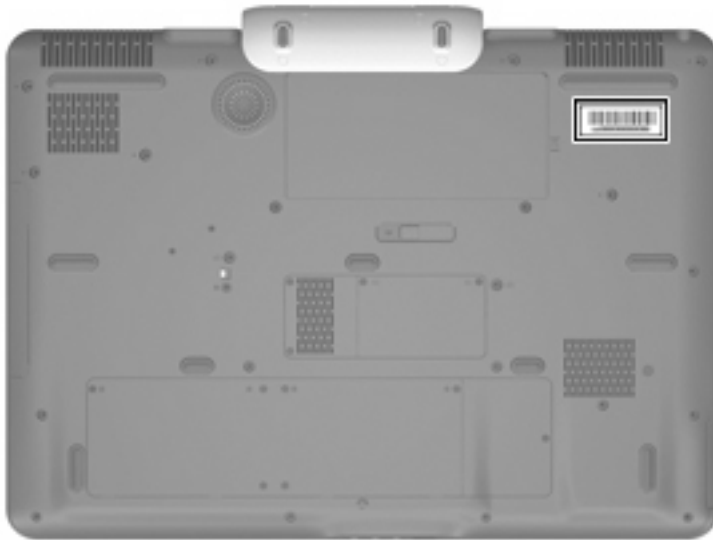

# Computer major components

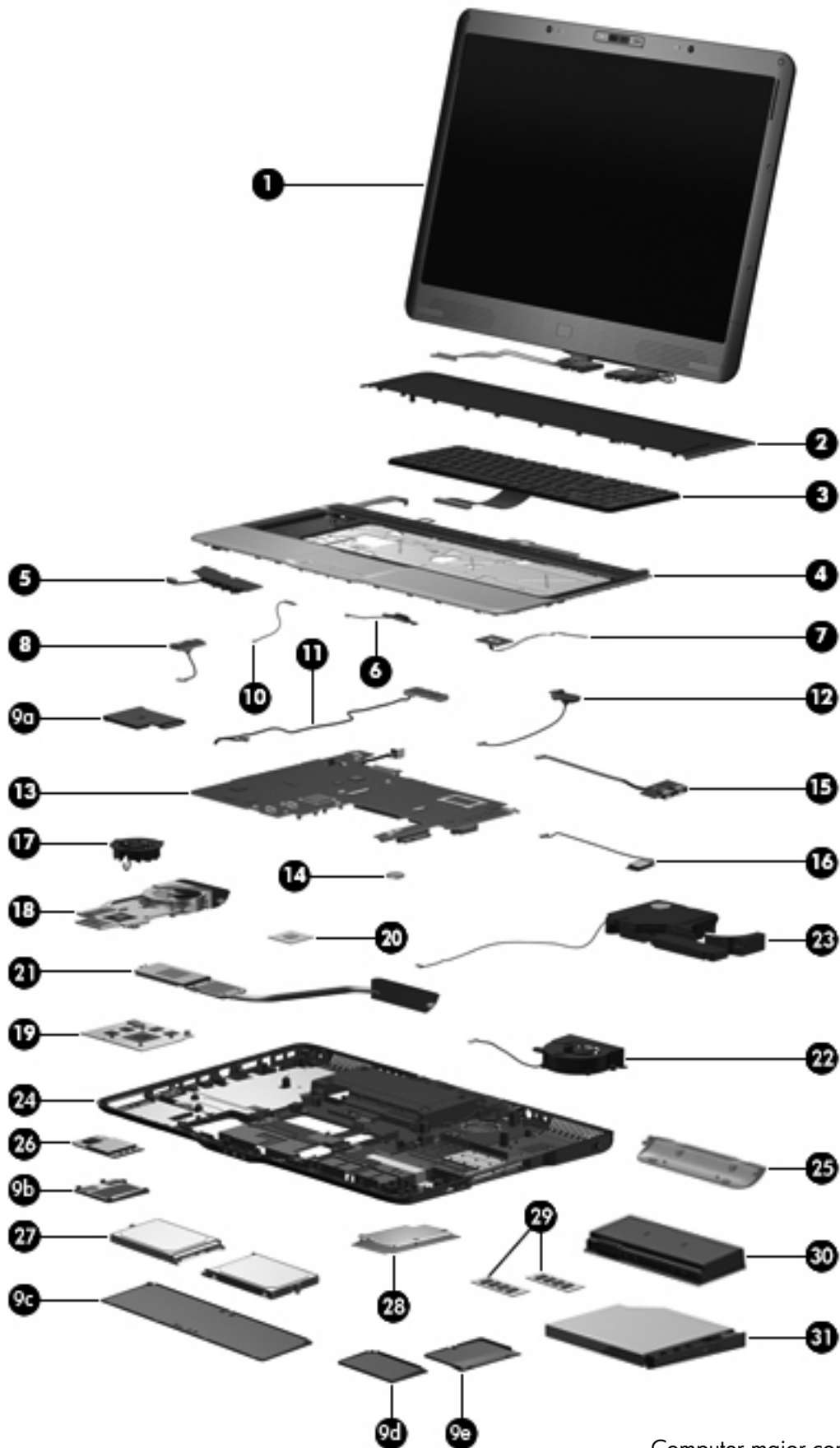

Item	Description	Spare part number
<b>(1)</b>	<b>Display assemblies</b> (include wireless antenna transceivers and cables, camera module and cable, speakers, and microphones and cables)	
	20.1-inch, WSXGA, TFT with BrightView	452299-001
	20.1-inch, WUXGA, TFT	452300-001
	<b>NOTE:</b> See <a href="#">Display assembly components on page 23</a> for more information on display assembly spare part numbers.	
<b>(2)</b>	<b>Rear cover</b>	448161-001
<b>(3)</b>	<b>Keyboards</b> (include keyboard cable)	
	For use in Denmark, Finland, Norway, and Sweden	448159-DH1
	For use in France	448159-051
	For use in French Canada	448159-121
	For use in Germany	448159-041
	For use in Italy	448159-061
	For use in Latin America	448159-161
	For use in the Netherlands and Europe	448159-B31
	For use in South Korea	448159-AD1
	For use in Spain	448159-071
	For use in the United Kingdom	448159-031
	For use in the United States	448159-001
<b>(4)</b>	<b>Top cover</b> (includes TouchPad board cable and TouchPad button cable, and LED boards and cables)	448174-001
<b>(5)</b>	<b>Audio/infrared board</b> (includes cable)	452316-001
<b>(6)</b>	<b>TouchPad on/off board</b> (includes cable)	448167-001
<b>(7)</b>	<b>Fingerprint reader board</b> (includes cable)	448166-001
<b>(8)</b>	<b>Rear USB board</b> (includes cable)	452315-001
	<b>Plastics Kit</b>	448171-001
<b>(9a)</b>	<b>ExpressCard slot bezel</b>	
<b>(9b)</b>	<b>WLAN module compartment cover</b>	
<b>(9c)</b>	<b>Hard drive bay cover</b>	
<b>(9d)</b>	<b>TV tuner module compartment cover</b>	
<b>(9e)</b>	<b>Memory module compartment cover</b>	
<b>(10)</b>	<b>Power connector LED board</b> (includes cable)	452318-001
<b>(11)</b>	<b>Audio connector board</b> (includes cable)	452317-001
<b>(12)</b>	<b>Video connector board</b> (includes cable)	452321-001
<b>(13)</b>	<b>System board</b> (includes power connector cable, ExpressCard assembly, and replacement thermal material)	448145-001

Item	Description	Spare part number
(14)	<b>RTC battery</b>	452319-001
(15)	<b>Front USB board</b> (includes cable)	452314-001
(16)	<b>Bluetooth module</b>	398393-002
	<b>NOTE:</b> The Bluetooth module spare part kit does not include a Bluetooth module cable. The Bluetooth module cable is available in the Cable Kit, spare part number 448169-001.	
(17)	<b>Video board fan</b>	448163-001
(18)	<b>Video board heat sink</b> (includes replacement thermal material)	448176-001
(19)	<b>nVidia video board</b> (includes replacement thermal material)	454311-001
(20)	<b>Processors</b>	
	<b>Intel Core 2 Extreme processors (4-MB L2 cache, 800-MHz FSB, 44-W):</b>	
	X7900 2.8-GHz processor	453908-001
	X7800 2.6-GHz processor	455738-001 and 452327-001
	<b>Intel Core 2 Duo processors (4-MB L2 cache, 800-MHz FSB, 35-W):</b>	
	T7700 2.4-GHz processor	448148-001
	T7500 2.2-GHz processor	448147-001
	T7300 2.0-GHz processor	448146-001
	T7100 1.8-GHz processor	448149-001
(21)	<b>Processor heat sink</b> (includes replacement thermal material)	448175-001
(22)	<b>Processor fan</b>	448162-001
(23)	<b>Subwoofer</b> (includes rubber isolators)	448164-001
(24)	<b>Base enclosure</b> (includes microphone and speaker extension cables and rubber feet)	448173-001
	<b>Rubber Feet Kit</b> (includes 11 computer feet in 4 sizes, and rubber screw covers)	452320-001
(25)	<b>Hinge cover</b>	452311-001
(26)	<b>WLAN modules</b>	
	<b>Intel 802.11a/b/g/n WLAN modules:</b>	
	<ul style="list-style-type: none"> <li>For use in Antigua &amp; Barbuda, Argentina, Aruba, the Bahamas, Barbados, Bermuda, Brunei, Canada, the Cayman Islands, Chile, Colombia, Costa Rica, the Dominican Republic, Ecuador, El Salvador, Guam, Guatemala, Haiti, Honduras, Hong Kong, India, Indonesia, Malaysia, Mexico, Panama, Paraguay, Peru, Saudi Arabia, Taiwan, Uruguay, the United States, Venezuela, and Vietnam</li> </ul>	441086-001
	<ul style="list-style-type: none"> <li>For use in Austria, Azerbaijan, Bahrain, Belgium, Brazil, Bulgaria, Croatia, Cyprus, the Czech Republic, Denmark, Egypt, Estonia, Finland, France, Georgia, Germany, Greece, Hungary, Iceland, Ireland, Israel, Italy, Latvia, Lebanon, Liechtenstein, Lithuania, Luxembourg, Malta, Monaco, the Netherlands, Norway, Oman, the Philippines, Poland, Portugal, Qatar, Romania, Russia, Serbia and Montenegro, Singapore, Slovakia, Slovenia, South Africa, Spain, Sri Lanka, Sweden, Switzerland, Turkey, Ukraine, the United Kingdom, and Uzbekistan</li> </ul>	441086-002
	<ul style="list-style-type: none"> <li>For use in Australia, New Zealand, Pakistan, the People's Republic of China, and South Korea</li> </ul>	441086-003

Item	Description	Spare part number
	<b>Intel 802.11 a/b/g WLAN modules:</b>	
	<ul style="list-style-type: none"> <li>For use in Antigua &amp; Barbuda, Argentina, Australia, the Bahamas, Barbados, Brunei, Canada, Chile, the Dominican Republic, Guam, Guatemala, Hong Kong, India, Indonesia, Malaysia, Mexico, New Zealand, Panama, Paraguay, Saudi Arabia, Taiwan, the United States, and Vietnam</li> </ul>	452063-001
	<ul style="list-style-type: none"> <li>For use in Aruba, Austria, Azerbaijan, Bahrain, Belgium, Bermuda, Brazil, Bulgaria, the Cayman Islands, Colombia, Croatia, Cyprus, the Czech Republic, Denmark, Egypt, El Salvador, Estonia, Finland, France, Georgia, Germany, Greece, Hungary, Iceland, Ireland, Italy, Jordan, Latvia, Lebanon, Liechtenstein, Lithuania, Luxembourg, Malta, Monaco, the Netherlands, Norway, Oman, the Philippines, Poland, Portugal, Romania, Russia, Serbia and Montenegro, Singapore, Slovakia, Slovenia, South Africa, Spain, Sri Lanka, Sweden, Switzerland, Turkey, the United Kingdom, and Uzbekistan</li> </ul>	452063-002
	<ul style="list-style-type: none"> <li>For use in Ecuador, Haiti, Honduras, Pakistan, Peru, the People's Republic of China, Qatar, South Korea, Uruguay, and Venezuela</li> </ul>	452063-003
<b>(27)</b>	<b>Hard drives</b> (include hard drive bracket)	
	250-GB, 5400-rpm	454605-001
	200-GB, 4200-rpm	448155-001
	160-GB, 5400-rpm	448154-001
	120-GB, 7200-rpm	445152-001
	120-GB, 5400-rpm	448153-001
	100-GB, 7200-rpm	452313-001
<b>(28)</b>	<b>TV tuner modules</b>	
	For use only in Europe, the Middle East, and Africa	448168-002
	For use only in North America	448168-001
<b>(29)</b>	<b>Memory modules</b> (PC2-5300, 667-MHz, DDR2)	
	2048-MB	448151-001
	1024-MB	448150-001
	512-MB	452312-001
<b>(30)</b>	<b>9-cell, 2.55-Ah, 83-Wh battery</b>	448158-001
<b>(31)</b>	<b>Optical drives</b> (include bezel and bracket)	
	DVD±RW and CD-RW Super Multi Double-Layer Combo Drive with LightScribe	448157-001
	HD-DVD Drive	448156-001
	<b>Cable Kit</b> (not illustrated)	448169-001

## Display assembly components

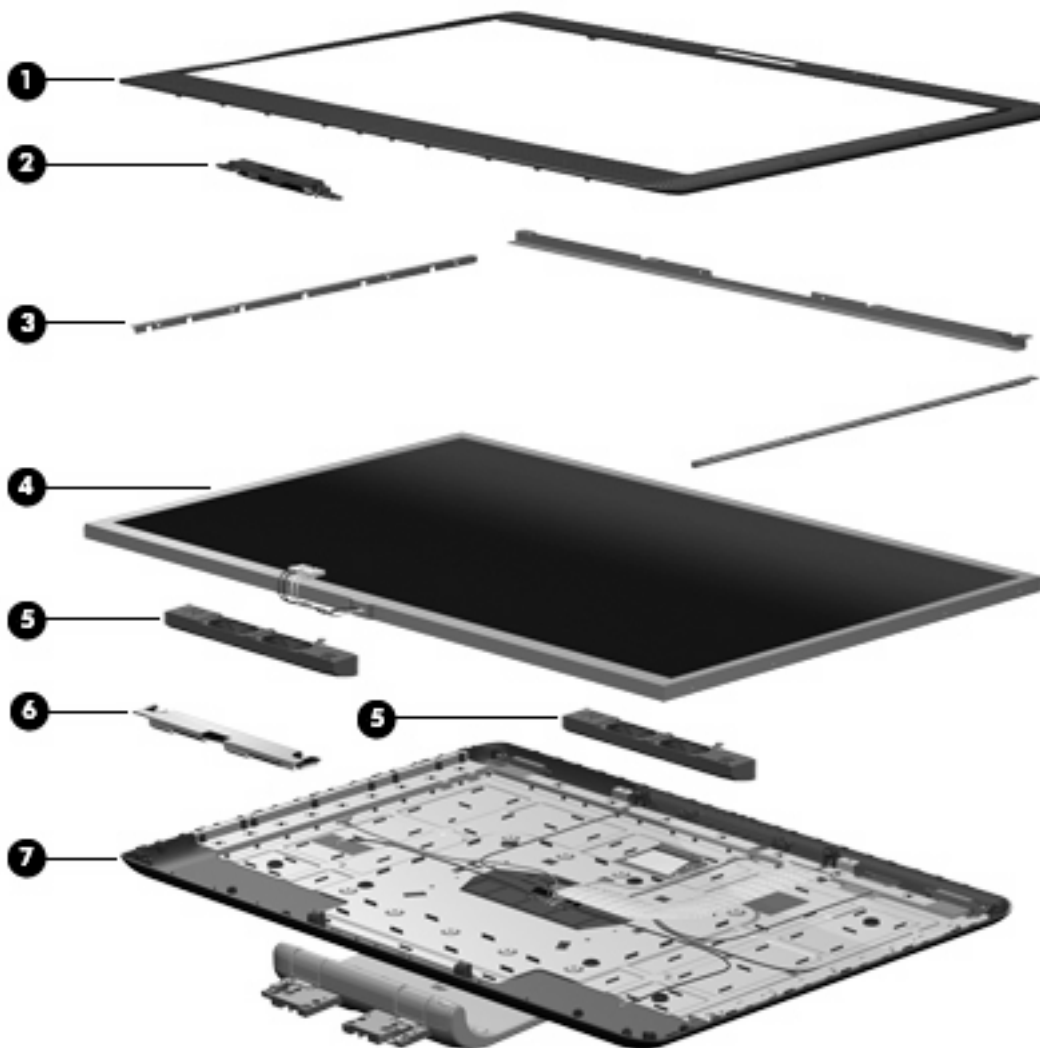

Item	Description	Spare part number
(1)	<b>Display bezel</b>	452307-001
(2)	<b>Camera module</b> (includes camera module brackets)	452304-001
(3)	<b>Display Bracket Kit</b> (includes left, top, and right brackets)	452303-001
(4)	<b>Display panels</b>	
	20.1-inch, WSXGA+, TFT, BrightView	452301-001
	20.1-inch, WUXGA, TFT	452302-001
(5)	<b>Speaker Kit</b> (includes left and right speakers)	452310-001
(6)	<b>Display inverter</b>	452308-001
(7)	<b>Display hinge/enclosure</b> (includes display panel cable and wireless antenna cables)	452306-001

Item	Description	Spare part number
	<b>Display Rubber Pad Kit</b> (not illustrated)	454595-001
	<b>Display Screw Kit</b> (not illustrated)	452309-001

## Plastics Kit

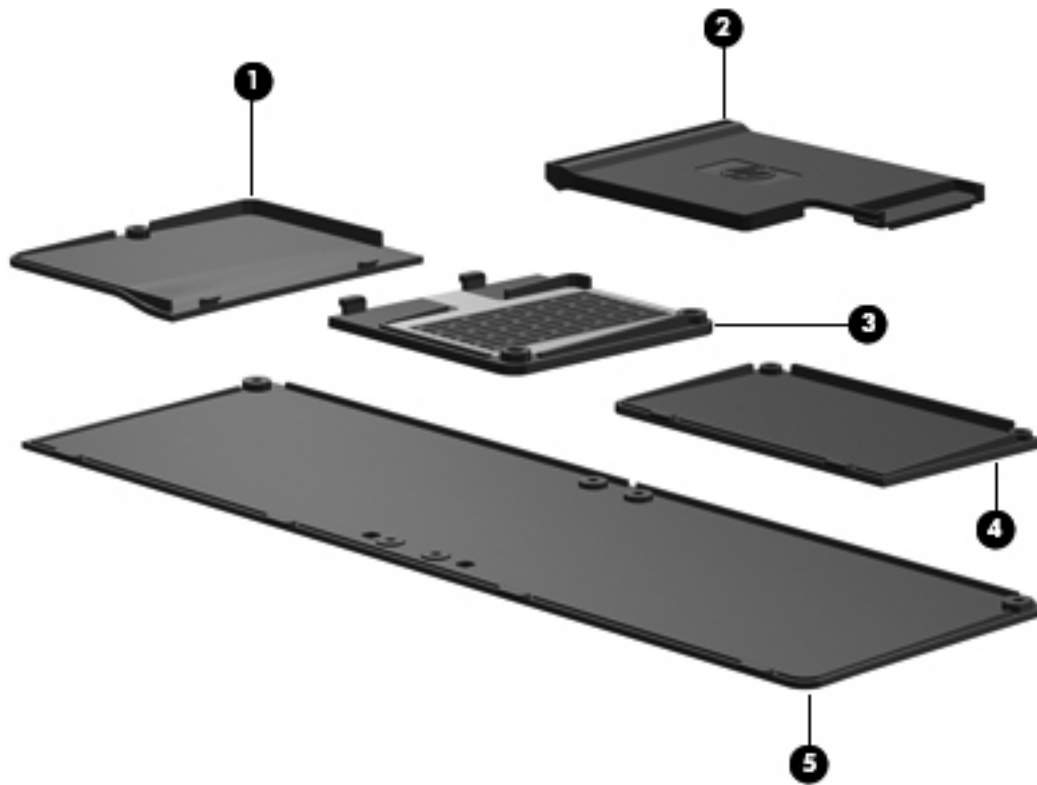

Item	Description	Spare part number
	<b>Plastics Kit</b>	448171-001
(1)	WLAN module compartment cover (includes 1 captive screw, secured by a C-clip)	
(2)	ExpressCard slot bezel	
(3)	TV tuner module compartment cover (includes 1 captive screw, secured by a C-clip)	
(4)	Memory module compartment cover (includes 2 captive screws, secured by C-clips)	
(5)	Hard drive bay cover (includes 2 captive screws, secured by C-clips)	



## Mass storage devices

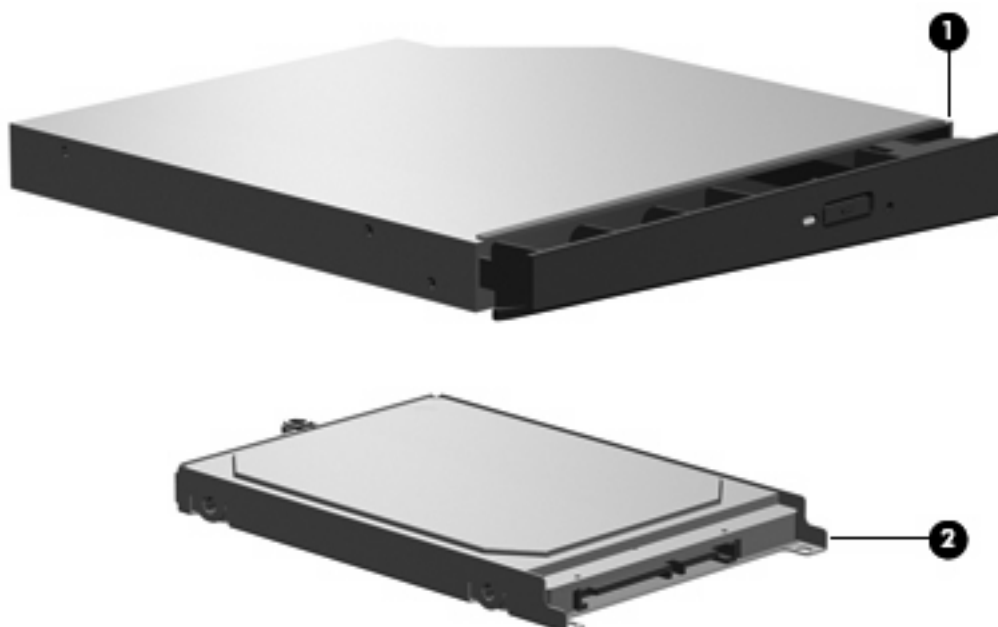

Item	Description	Spare part number
<b>(1)</b>	<b>Optical drives</b> (include bezel and bracket)	
	DVD±RW and CD-RW Super Multi Double-Layer Combo Drive with LightScribe	448157-001
	HD-DVD Drive	448156-001
<b>(2)</b>	<b>Hard drives</b> (include hard drive bracket)	
	250-GB, 5400-rpm	454605-001
	200-GB, 4200-rpm	448155-001
	160-GB, 5400-rpm	448154-001
	120-GB, 7200-rpm	448152-001
	120-GB, 5400-rpm	448153-001
	100-GB, 7200-rpm	452313-001

## Miscellaneous parts

Description	Spare part number
<b>180-W PFC AC adapter</b>	448160-001
<b>ATSC/NTSC TV tuner antenna</b>	439131-001
<b>ATSC/NTSC/PAL TV tuner</b>	439130-001
<b>Bluetooth headset</b>	443783-001
<b>Composite video cable</b>	407939-001
<b>DVB-T tuner</b>	412175-001
<b>DVB-T antenna adapter</b>	412176-001
<b>ExpressCard Kit</b> (includes software CD)	445170-001
<b>Infrared emitter with cable</b>	439129-001
<b>Optical wired mouse</b>	436238-001
<b>Remote controls</b>	
For use in Europe, the Middle East, and Africa	448165-002
For use in North America	448165-001
<b>RF input adapter cable</b> (without ferrite)	407940-001
<b>USB digital drive</b>	364727-002
<b>Wired headset</b>	371693-001 and 371693-003
<b>Wireless laser mouse</b> (includes cable adapter)	430958-001
<b>Power cords:</b>	
Australia and New Zealand	436848-011
Belgium, Europe, Finland, France, Germany, Greece, the Netherlands, Norway, Portugal, Spain, and Sweden	436848-021
Canada, French Canada, Latin America, Thailand, and the United States	436848-001
Denmark	436848-081
India	436848-D61
Italy	436848-061
South Korea	436848-AD1
The United Kingdom and Hong Kong	436848-031
<b>Screw Kit</b>	448172-001
<ul style="list-style-type: none"> <li>• Phillips PM3.0×12.0 screw</li> <li>• Phillips PM3.0×8.0 screw</li> <li>• Phillips PM3.0×4.0 screw</li> <li>• Phillips PM2.5×13.0 captive screw</li> </ul>	

Description	Spare part number
• Phillips PM2.5×12.0 captive screw	
• Phillips PM2.5×11.0 screw	
• Phillips PM2.5×8.0 captive screw	
• Phillips PM2.5×8.0 screw	
• Phillips PM2.5×5.0 screw	
• Phillips PM2.5×4.0 screw	
• Phillips PM2.5×3.0 broad-head screw	
• Black Phillips PM2.0×5.0 captive screw	
• Silver Phillips PM2.0×5.0 captive screw	
• Black Phillips PM2.0×4.0 screw	
• Silver Phillips PM2.0×4.0 screw	
• Phillips PM2.0×3.0 screw	
• Slotted SM1.5×9.0 shoulder screw	

## Sequential part number listing

Spare part number	Description
371693-001	Wired headset with volume control
371693-003	Wired headset with volume control (glossy black)
398393-002	Bluetooth module
	<b>NOTE:</b> The Bluetooth module spare part kit does not include a Bluetooth module cable. The Bluetooth module cable is available in the Cable Kit, spare part number 448169-001.
413706-001	Thermal Material Kit
436848-001	2-wire power cord for use in the United States
436848-011	2-wire power cord for use in Australia
436848-021	2-wire power cord for use in Europe
436848-031	2-wire power cord for use in the United Kingdom
436848-061	2-wire power cord for use in Italy
436848-081	2-wire power cord for use in Denmark
436848-AD1	2-wire power cord for use in South Korea
436848-D61	2-wire power cord for use in India
441086-001	Intel 802.11a/b/g/n WLAN module for use in Antigua & Barbuda, Argentina, Aruba, the Bahamas, Barbados, Bermuda, Brunei, Canada, the Cayman Islands, Chile, Colombia, Costa Rica, the Dominican Republic, Ecuador, El Salvador, Guam, Guatemala, Haiti, Honduras, Hong Kong, India, Indonesia, Malaysia, Mexico, Panama, Paraguay, Peru, Saudi Arabia, Taiwan, Uruguay, the United States, Venezuela, and Vietnam

<b>Spare part number</b>	<b>Description</b>
441086-002	Intel 802.11a/b/g/n WLAN module for use in Austria, Azerbaijan, Bahrain, Belgium, Brazil, Bulgaria, Croatia, Cyprus, the Czech Republic, Denmark, Egypt, Estonia, Finland, France, Georgia, Germany, Greece, Hungary, Iceland, Ireland, Israel, Italy, Latvia, Lebanon, Liechtenstein, Lithuania, Luxembourg, Malta, Monaco, the Netherlands, Norway, Oman, the Philippines, Poland, Portugal, Qatar, Romania, Russia, Serbia and Montenegro, Singapore, Slovakia, Slovenia, South Africa, Spain, Sri Lanka, Sweden, Switzerland, Turkey, Ukraine, the United Kingdom, and Uzbekistan
441086-003	Intel 802.11a/b/g/n WLAN module for use in Australia, New Zealand, Pakistan, the People's Republic of China, and South Korea
443783-001	Bluetooth headset
448145-001	System board (includes power connector cable, ExpressCard assembly, and replacement thermal material)
448146-001	Intel Core 2 Duo T7300 2.0-GHz processor (includes replacement thermal material)
448147-001	Intel Core 2 Duo T7500 2.2-GHz processor (includes replacement thermal material)
448148-001	Intel Core 2 Duo T7700 2.4-GHz processor (includes replacement thermal material)
448149-001	Intel Core 2 Duo T7100 1.8-GHz processor (includes replacement thermal material)
448150-001	1024-MB memory module (PC2-5300, 667-MHz, DDR2)
448151-001	2048-MB memory module (PC2-5300, 667-MHz, DDR2)
448152-001	120-GB, 7200-rpm hard drive (includes hard drive bracket)
448153-001	120-GB, 5400-rpm hard drive (includes hard drive bracket)
448154-001	160-GB, 5400-rpm hard drive (includes hard drive bracket)
448155-001	200-GB, 4200-rpm hard drive (includes hard drive bracket)
448156-001	HD-DVD Drive (includes bezel and bracket)
448157-001	DVD±RW and CD-RW Super Multi Double-Layer Combo Drive with LightScribe (includes bezel and bracket)
448158-001	Battery, 9-cell, 2.55-Ah, 83-Wh
448159-001	Keyboard for use in the United States
448159-031	Keyboard for use in the United Kingdom
448159-041	Keyboard for use in France
448159-051	Keyboard for use in Germany
448159-061	Keyboard for use in Italy
448159-071	Keyboard for use in Spain
448159-121	Keyboard for use in French Canada
448159-161	Keyboard for use in Latin America
448159-AD1	Keyboard for use in South Korea
448159-B31	Keyboard for use in the Netherlands and Europe
448159-DH1	Keyboard for use in Denmark, Finland, Norway, and Sweden
448160-001	180-W AC adapter
448161-001	Rear cover

<b>Spare part number</b>	<b>Description</b>
448162-001	Processor fan
448163-001	Video board fan
448164-001	Subwoofer (includes rubber isolators)
448165-001	Remote control for use in North America
448165-002	Remote control for use in Europe, the Middle East, and Africa
448166-001	Fingerprint reader board (includes cable)
448167-001	TouchPad on/off board (includes cable)
448168-001	TV tuner module for use in North America
448168-002	TV tuner module for use in Europe, the Middle East, and Africa
448169-001	Cable Kit
448171-001	Plastics Kit (see <a href="#">Plastics Kit on page 24</a> for more Plastics Kit information)
448172-001	Screw Kit
448173-001	Base enclosure (includes microphone and speaker extension cables and rubber feet)
448174-001	Top cover (includes TouchPad board cable and TouchPad button cable, and LED boards and cables)
448175-001	Processor heat sink (includes replacement thermal material)
448176-001	Video board heat sink (includes replacement thermal material)
452063-001	Intel 802.11a/b/g WLAN module for use in Antigua & Barbuda, Argentina, Aruba, the Bahamas, Barbados, Bermuda, Brunei, Canada, the Cayman Islands, Chile, Colombia, Costa Rica, the Dominican Republic, Ecuador, El Salvador, Guam, Guatemala, Haiti, Honduras, Hong Kong, India, Indonesia, Malaysia, Mexico, Panama, Paraguay, Peru, Saudi Arabia, Taiwan, Uruguay, the United States, Venezuela, and Vietnam
452063-002	Intel 802.11a/b/g WLAN module for use in Austria, Azerbaijan, Bahrain, Belgium, Brazil, Bulgaria, Croatia, Cyprus, the Czech Republic, Denmark, Egypt, Estonia, Finland, France, Georgia, Germany, Greece, Hungary, Iceland, Ireland, Israel, Italy, Latvia, Lebanon, Liechtenstein, Lithuania, Luxembourg, Malta, Monaco, the Netherlands, Norway, Oman, the Philippines, Poland, Portugal, Qatar, Romania, Russia, Serbia and Montenegro, Singapore, Slovakia, Slovenia, South Africa, Spain, Sri Lanka, Sweden, Switzerland, Turkey, Ukraine, the United Kingdom, and Uzbekistan
452063-003	Intel 802.11a/b/g WLAN module for use in Australia, New Zealand, Pakistan, the People's Republic of China, and South Korea
452299-001	20.1-inch, WSXGA BrightView display assembly (includes camera module and cable, microphones, speakers, and WLAN antennae)
452300-001	20.1-inch, WUXGA BrightView display assembly (includes camera module and cable, microphones, speakers, and WLAN antennae)
452301-001	20.1-inch, WSXGA BrightView display panel
452302-001	20.1-inch, WUXGA BrightView display panel
452303-001	Display Bracket Kit
452304-001	Camera module and camera module bracket
452306-001	Display hinge/enclosure (includes display cables)
452307-001	Display bezel (includes logos)
452308-001	Display inverter

<b>Spare part number</b>	<b>Description</b>
452309-001	Display Screw Kit
452310-001	Speaker Kit (includes left and right speakers)
452311-001	Hinge cover
452312-001	512-MB memory module (PC2-5300, 667-MHz, DDR2)
452313-001	100-GB, 7200-rpm hard drive (includes hard drive bracket)
452314-001	Front USB board (includes cable)
452315-001	Rear USB board (includes cable)
452316-001	Audio/infrared board (includes cable)
452317-001	Audio connector board (includes cable)
452318-001	Power connector LED board (includes cable)
452319-001	RTC battery
452320-001	Rubber Feet Kit (includes 11 computer feet in 4 sizes, and rubber screw covers)
452321-001	Video connector board (includes cable)
452322-001	nVidia video board (includes replacement thermal material)
452327-001	Intel Core 2 Extreme X7800 2.6-GHz processor (includes replacement thermal material)
453908-001	Intel Core 2 Extreme X7900 2.8-GHz processor (includes replacement thermal material)
454311-001	nVidia video board (includes replacement thermal material)
454595-001	Display Rubber Pad Kit
454605-001	250-GB, 5400-rpm hard drive (includes hard drive bracket)
455738-001	Intel Core 2 Extreme X7800 2.6-GHz processor (includes replacement thermal material)

---

# 4 Removal and replacement procedures

## Preliminary replacement requirements

### Tools required

You will need the following tools to complete the removal and replacement procedures:

- Magnetic screwdriver
- Phillips P0 and P1 screwdrivers
- Flat-bladed screwdriver

### Service considerations

The following sections include some of the considerations that you must keep in mind during disassembly and assembly procedures.

---

 **NOTE:** As you remove each subassembly from the computer, place the subassembly (and all accompanying screws) away from the work area to prevent damage.

---

### Plastic parts

Using excessive force during disassembly and reassembly can damage plastic parts. Use care when handling the plastic parts. Apply pressure only at the points designated in the maintenance instructions.

## Cables and connectors

- 
- △ **CAUTION:** When servicing the computer, be sure that cables are placed in their proper locations during the reassembly process. Improper cable placement can damage the computer.
- 

Cables must be handled with extreme care to avoid damage. Apply only the tension required to unseat or seat the cables during removal and insertion. Handle cables by the connector whenever possible. In all cases, avoid bending, twisting, or tearing cables. Be sure that cables are routed in such a way that they cannot be caught or snagged by parts being removed or replaced. Handle flex cables with extreme care; these cables tear easily.

## Drive handling

- 
- △ **CAUTION:** Drives are fragile components that must be handled with care. To prevent damage to the computer, damage to a drive, or loss of information, observe these precautions:
- 

Before removing or inserting a hard drive, shut down the computer. If you are unsure whether the computer is off or in Hibernation, turn the computer on, and then shut it down through the operating system.

Before handling a drive, be sure that you are discharged of static electricity. While handling a drive, avoid touching the connector.

Before removing a diskette drive or optical drive, be sure that a diskette or disc is not in the drive and be sure that the optical drive tray is closed.

Handle drives on surfaces covered with at least one inch of shock-proof foam.

Avoid dropping drives from any height onto any surface.

After removing a hard drive, an optical drive, or a diskette drive, place it in a static-proof bag.

Avoid exposing a hard drive to products that have magnetic fields, such as monitors or speakers.

Avoid exposing a drive to temperature extremes or liquids.

If a drive must be mailed, place the drive in a bubble pack mailer or other suitable form of protective packaging and label the package "FRAGILE."

---



# Grounding guidelines

## Electrostatic discharge damage

Electronic components are sensitive to electrostatic discharge (ESD). Circuitry design and structure determine the degree of sensitivity. Networks built into many integrated circuits provide some protection, but in many cases, ESD contains enough power to alter device parameters or melt silicon junctions.

A discharge of static electricity from a finger or other conductor can destroy static-sensitive devices or microcircuitry. Even if the spark is neither felt nor heard, damage may have occurred.

An electronic device exposed to ESD may not be affected at all and can work perfectly throughout a normal cycle. Or the device may function normally for a while, then degrade in the internal layers, reducing its life expectancy.

△ **CAUTION:** To prevent damage to the computer when you are removing or installing internal components, observe these precautions:

Keep components in their electrostatic-safe containers until you are ready to install them.

Use nonmagnetic tools.

Before touching an electronic component, discharge static electricity by using the guidelines described in this section.

Avoid touching pins, leads, and circuitry. Handle electronic components as little as possible.

If you remove a component, place it in an electrostatic-safe container.

The following table shows how humidity affects the electrostatic voltage levels generated by different activities.

△ **CAUTION:** A product can be degraded by as little as 700 V.

Typical electrostatic voltage levels			
Event	Relative humidity		
	10%	40%	55%
Walking across carpet	35,000 V	15,000 V	7,500 V
Walking across vinyl floor	12,000 V	5,000 V	3,000 V
Motions of bench worker	6,000 V	800 V	400 V
Removing DIPS from plastic tube	2,000 V	700 V	400 V
Removing DIPS from vinyl tray	11,500 V	4,000 V	2,000 V
Removing DIPS from Styrofoam	14,500 V	5,000 V	3,500 V
Removing bubble pack from PCB	26,500 V	20,000 V	7,000 V
Packing PCBs in foam-lined box	21,000 V	11,000 V	5,000 V

## Packaging and transporting guidelines

Follow these grounding guidelines when packaging and transporting equipment:

- To avoid hand contact, transport products in static-safe tubes, bags, or boxes.
- Protect ESD-sensitive parts and assemblies with conductive or approved containers or packaging.
- Keep ESD-sensitive parts in their containers until the parts arrive at static-free workstations.
- Place items on a grounded surface before removing items from their containers.
- Always be properly grounded when touching a component or assembly.
- Store reusable ESD-sensitive parts from assemblies in protective packaging or nonconductive foam.
- Use transporters and conveyors made of antistatic belts and roller bushings. Be sure that mechanized equipment used for moving materials is wired to ground and that proper materials are selected to avoid static charging. When grounding is not possible, use an ionizer to dissipate electric charges.

## Workstation guidelines

Follow these grounding workstation guidelines:

- Cover the workstation with approved static-shielding material.
- Use a wrist strap connected to a properly grounded work surface and use properly grounded tools and equipment.
- Use conductive field service tools, such as cutters, screwdrivers, and vacuums.
- When fixtures must directly contact dissipative surfaces, use fixtures made only of static-safe materials.
- Keep the work area free of nonconductive materials, such as ordinary plastic assembly aids and Styrofoam.
- Handle ESD-sensitive components, parts, and assemblies by the case or PCM laminate. Handle these items only at static-free workstations.
- Avoid contact with pins, leads, or circuitry.
- Turn off power and input signals before inserting or removing connectors or test equipment.

## Equipment guidelines

Grounding equipment must include either a wrist strap or a foot strap at a grounded workstation.

- When seated, wear a wrist strap connected to a grounded system. Wrist straps are flexible straps with a minimum of one megohm  $\pm 10\%$  resistance in the ground cords. To provide proper ground, wear a strap snugly against the skin at all times. On grounded mats with banana-plug connectors, use alligator clips to connect a wrist strap.
- When standing, use foot straps and a grounded floor mat. Foot straps (heel, toe, or boot straps) can be used at standing workstations and are compatible with most types of shoes or boots. On conductive floors or dissipative floor mats, use foot straps on both feet with a minimum of one megohm resistance between the operator and ground. To be effective, the conductive strips must be worn in contact with the skin.

The following grounding equipment is recommended to prevent electrostatic damage:

- Antistatic tape
- Antistatic smocks, aprons, and sleeve protectors
- Conductive bins and other assembly or soldering aids
- Nonconductive foam
- Conductive tabletop workstations with ground cords of one megohm resistance
- Static-dissipative tables or floor mats with hard ties to the ground
- Field service kits
- Static awareness labels
- Material-handling packages
- Nonconductive plastic bags, tubes, or boxes
- Metal tote boxes
- Electrostatic voltage levels and protective materials

The following table lists the shielding protection provided by antistatic bags and floor mats.

Material	Use	Voltage protection level
Antistatic plastic	Bags	1,500 V
Carbon-loaded plastic	Floor mats	7,500 V
Metallized laminate	Floor mats	5,000 V

## Unknown user password

If the computer you are servicing has an unknown user password, follow these steps to clear the password.

 **NOTE:** These steps also clear CMOS.

---

Before disassembling the computer, follow these steps:

1. Shut down the computer. If you are unsure whether the computer is off or in Hibernation, turn the computer on, and then shut it down through the operating system.
2. Disconnect all external devices connected to the computer.
3. Disconnect the power from the computer by first unplugging the power cord from the AC outlet and then unplugging the AC adapter from the computer.
4. Remove the battery (see [Battery on page 38](#)).
5. Remove the RTC battery (see [RTC battery on page 81](#)).
6. Wait approximately 5 minutes.
7. Replace the RTC battery and reassemble the computer.
8. Connect AC power to the computer. Do not reinsert any batteries at this time.
9. Turn on the computer.

All passwords and all CMOS settings have been cleared.

# Component replacement procedures

This chapter provides removal and replacement procedures.

There are as many as 154 screws, in 18 different sizes, that must be removed, replaced, or loosened when servicing the computer. Make special note of each screw size and location during removal and replacement.

## Serial number

Report the computer serial number to HP when requesting information or ordering spare parts. The serial number is located on the bottom of the computer.

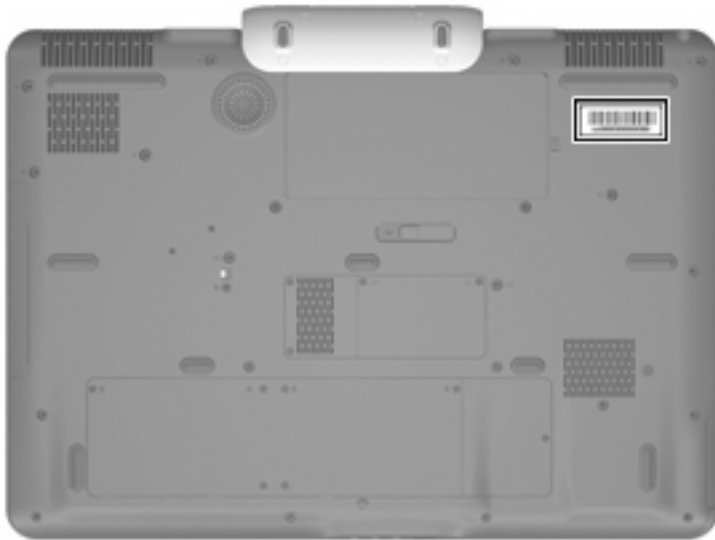

## Battery

Description	Spare part number
9-cell, 2.55-Ah, 83-Wh battery	448158-001

Before disassembling the computer, follow these steps:

1. Shut down the computer. If you are unsure whether the computer is off or in Hibernation, turn the computer on, and then shut it down through the operating system.
2. Disconnect all external devices connected to the computer.
3. Disconnect the power from the computer by first unplugging the power cord from the AC outlet and then unplugging the AC adapter from the computer.

Remove the battery:

1. Turn the computer upside down on a flat surface.
2. Slide the battery release latch **(1)** to release the battery.
3. Pivot the battery **(2)** upward and remove it from the computer **(3)**.

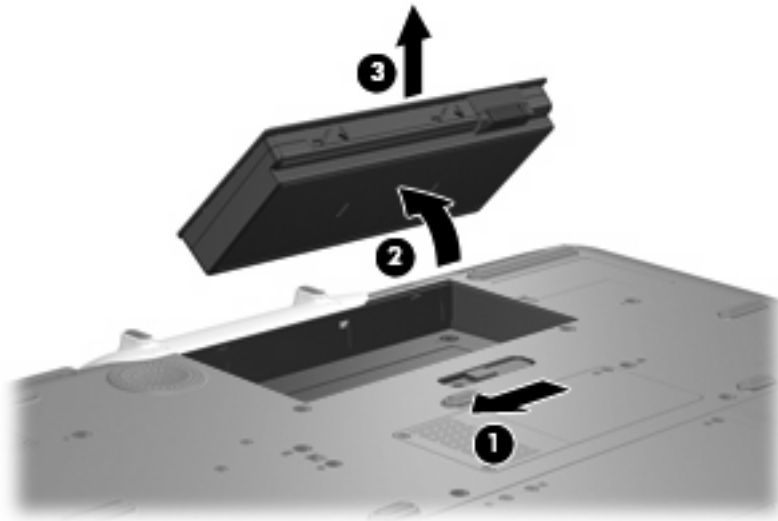

To insert the battery, insert the rear edge of the battery into the battery bay and pivot the front edge of the battery downward until it is seated. The battery release latch automatically locks the battery into place.

## Computer feet

Description	Spare part number
Rubber Feet Kit (includes 11 computer feet in 4 sizes)	452320-001

The computer feet are adhesive-backed rubber pads. The feet attach to the base enclosure in the locations illustrated below.

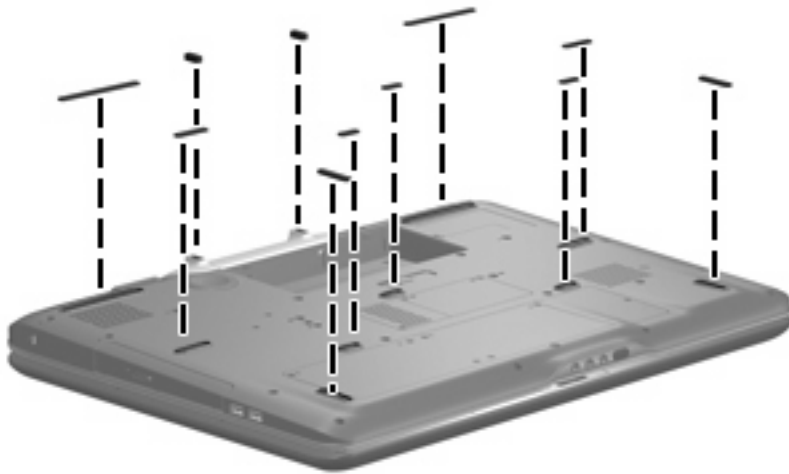

## Display assembly internal components

 **NOTE:** If it has been determined that the display bezel, camera module, display inverter, display panel, or speakers are the components that must be replaced to complete the computer repair, the display assembly does not have to be completely removed from the computer. Replacement of these components can be completed by removing only the display bezel. Follow the procedures in this section to replace the display bezel, camera module, display inverter, display panel, or speakers. For information on replacing the entire display assembly, see [Display assembly on page 64](#).

Before removing the display bezel, follow these steps:

1. Shut down the computer. If you are unsure whether the computer is off or in Hibernation, turn the computer on, and then shut it down through the operating system.
2. Disconnect all external devices connected to the computer.
3. Disconnect the power from the computer by first unplugging the power cord from the AC outlet and then unplugging the AC adapter from the computer.
4. Remove the battery (see [Battery on page 38](#)).

Remove the display bezel:

1. Turn the computer display-side up, with the rear panel toward you.
2. Open the computer as far as possible.
3. Remove the two rubber screw covers from the back of the display assembly **(1)**. All rubber screw covers and logo labels removed in this section are included in the Display Rubber Pad Kit, spare part number 454595-001.
4. Remove the two Phillips 2.5×5.0 screws **(2)** that secure the display bezel to the display enclosure.

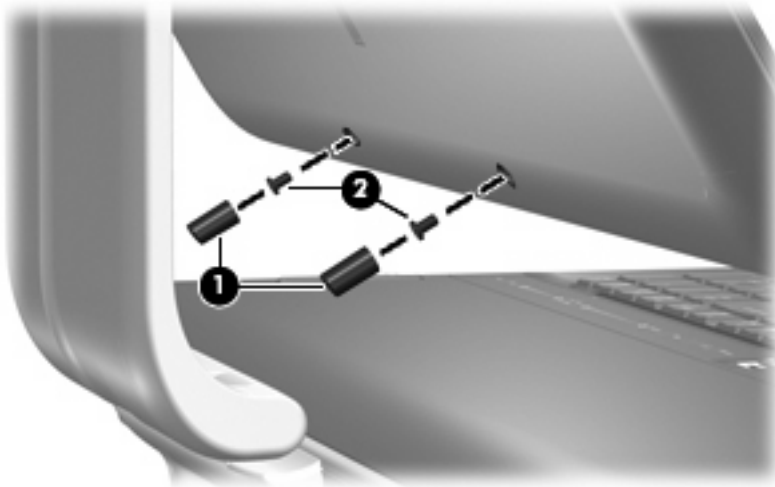

5. Position the computer with the front toward you.



6. Remove the following screw covers and logo labels:
  - (1) Two rubber screw covers on the display bezel top edge corners
  - (2) Two rubber screw covers on the display bezel top edge
  - (3) Four rubber screw covers on the display bezel left and right sides
  - (4) Speaker logo label on the display bezel lower left edge
  - (5) Computer model logo label on the display bezel lower right edge

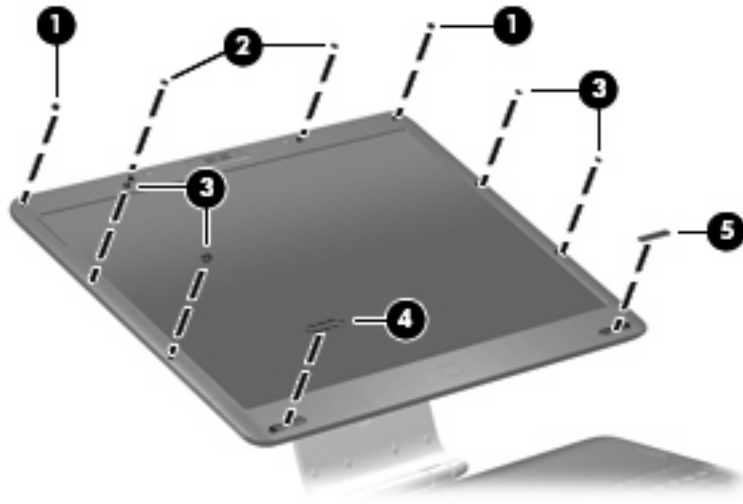

7. Remove the ten Phillips PM2.5×5.0 screws that secure the display bezel to the display assembly.

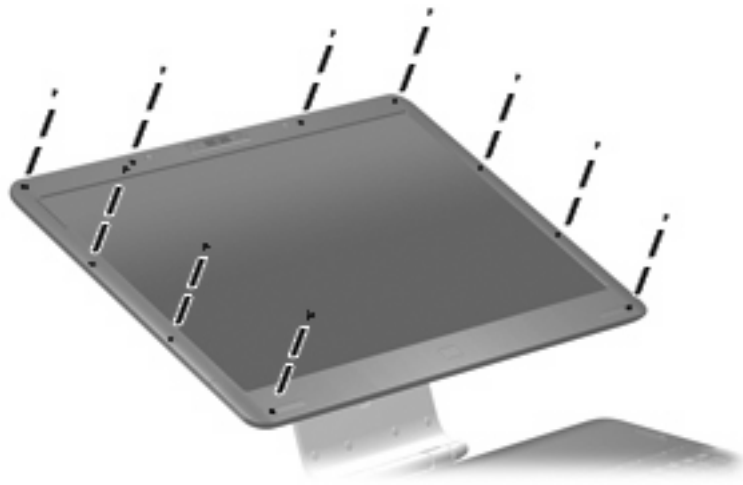

8. Flex the inside edges of the left and right sides (1) and the top and bottom edges (2) of the display bezel until the bezel disengages from the display enclosure.

9. Remove the display bezel **(3)**. The display bezel is available using spare part number 452307-001.

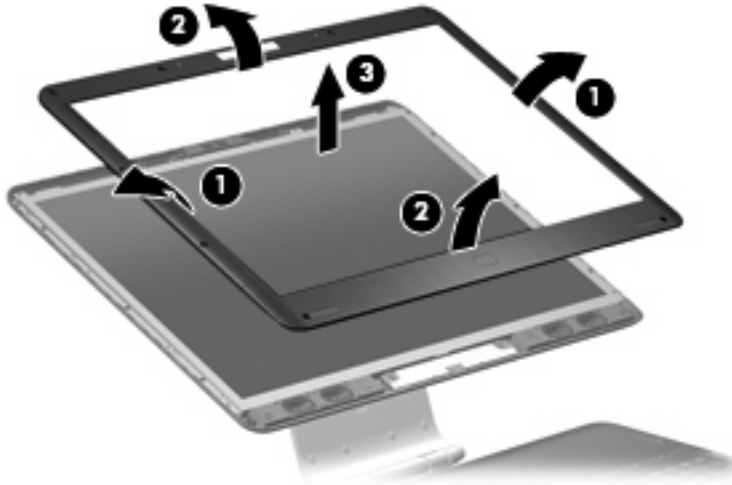

10. If it is necessary to replace the camera module, remove the two Phillips PM2.5×5.0 screws **(1)** that secure the camera module to the display enclosure.
11. Release the camera module **(2)** from the display enclosure as far as the camera module cable allows.
12. Disconnect the camera module cable **(3)** from the camera module.

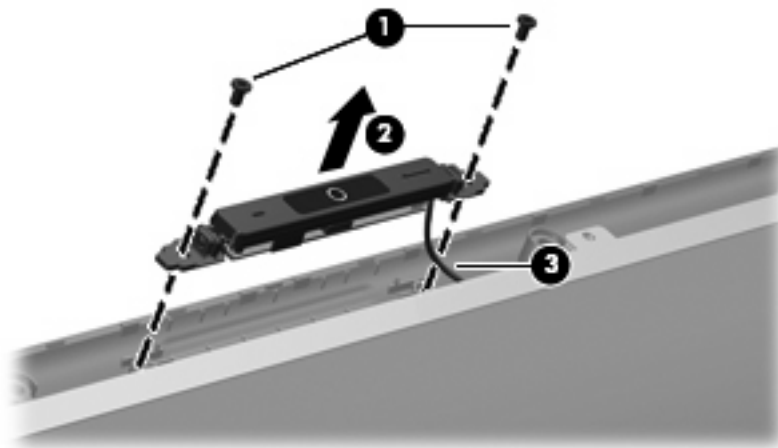

13. Remove the camera module. The camera module is available using spare part number 452304-001.
14. If it is necessary to replace the display inverter, remove the display inverter **(1)** from the display enclosure as far as the two display inverter cables and the backlight cable allow.

15. Disconnect the two display panel cables **(2)** and the backlight cable **(3)** from the display inverter.

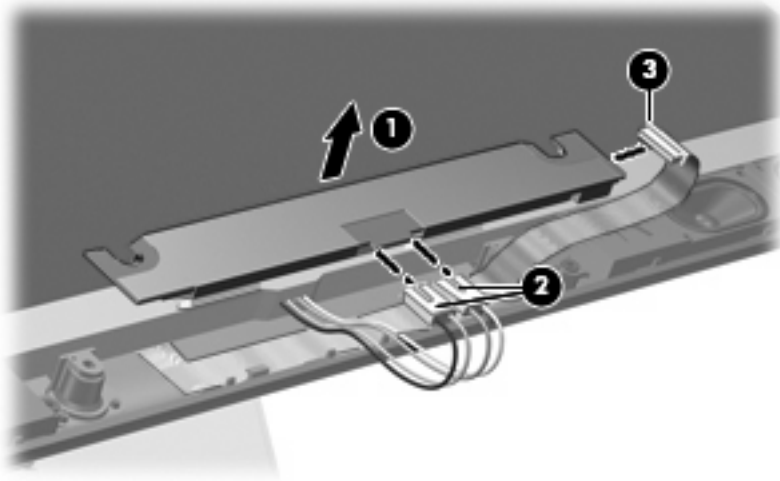

16. Remove the display inverter. The display inverter is available using spare part number 452308-001.
17. If it is necessary to replace the display panel, remove the eight Phillips PM2.5×5.0 screws that secure the display panel to the display enclosure.

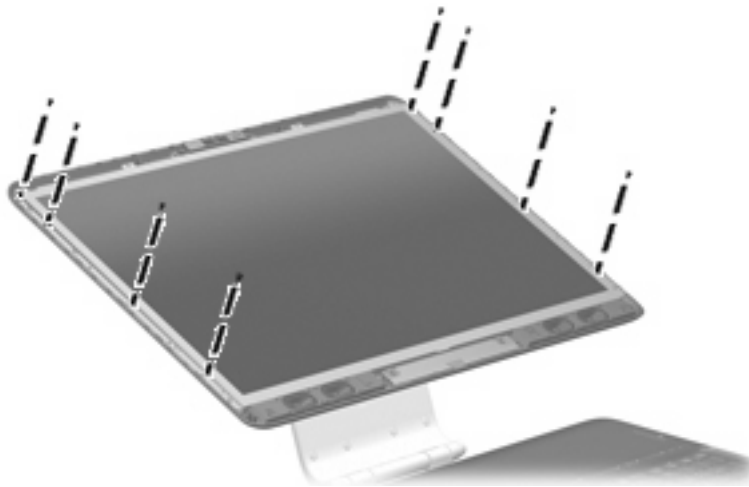

18. Tilt the top edge of the display panel **(1)** forward until the display panel cable connector is accessible.

19. Squeeze the tabs on the display panel cable connector **(2)** together and disconnect the cable **(3)** from the display panel.



20. Remove the display panel. The display panel is available using spare part numbers 452301-001 (20.1-inch, WSXGA+BrightView) and 452302-001 (20.1-inch, WUXGA).
21. If it is necessary to replace the speakers, disconnect the speaker cable connectors **(1)** from the speaker extension cable connectors.
22. Remove the two Phillips PM2.5x5.0 screws **(2)** that secure each speaker to the display enclosure.
23. Remove the speakers **(3)**. The speakers are available using spare part number 452310-001

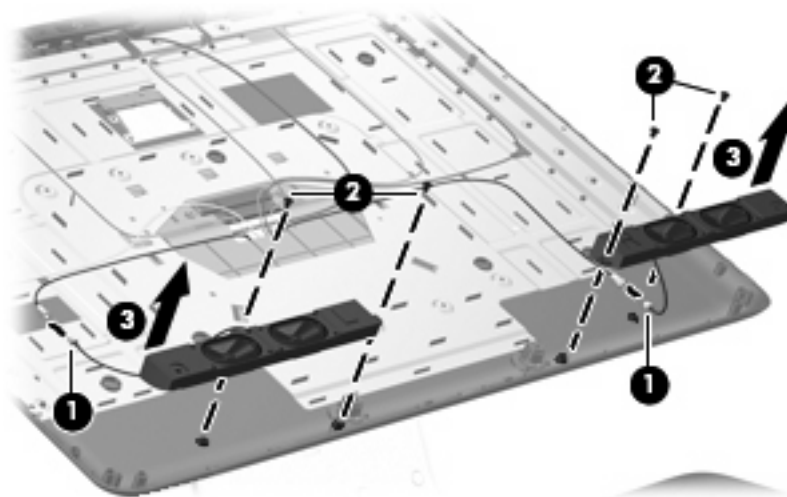

Reverse this procedure to install the display bezel, camera module, display inverter, display panel, and speakers.

## Hard drive

 **NOTE:** All hard drive spare part kits include a hard drive bracket.

Description	Spare part number
250-GB, 5400-rpm	454605-001
200-GB, 4200-rpm	448155-001
160-GB, 5400-rpm	448154-001
120-GB, 7200-rpm	448152-001
120-GB, 5400-rpm	448153-001
100-GB, 7200-rpm	452313-001

Before removing the hard drive, follow these steps:

1. Shut down the computer. If you are unsure whether the computer is off or in Hibernation, turn the computer on, and then shut it down through the operating system.
2. Disconnect all external devices connected to the computer.
3. Disconnect the power from the computer by first unplugging the power cord from the AC outlet and then unplugging the AC adapter from the computer.
4. Remove the battery (see [Battery on page 38](#)).

Remove the hard drive:

1. Loosen the six black Phillips PM2.0×5.0 captive screws **(1)** that secure the hard drive bay cover to the computer.
2. Lift the rear edge of the hard drive bay cover **(2)**, swing it forward, and remove the cover. The hard drive bay cover is included in the Plastics Kit, spare part number 448171-001.

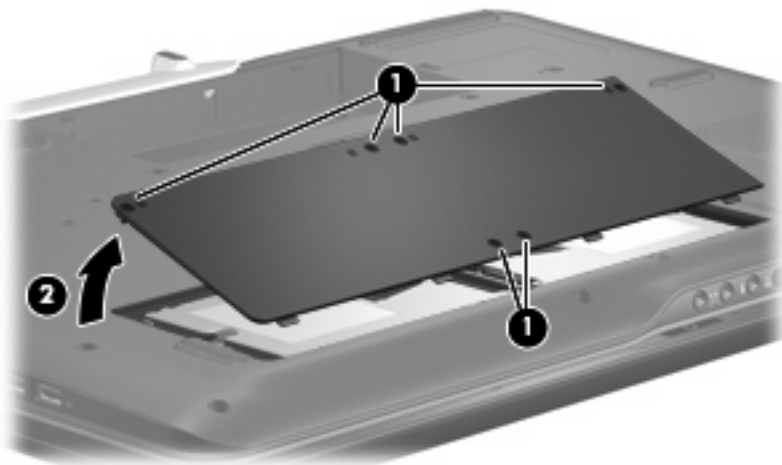

3. Loosen the Phillips PM2.5×12.0 screw **(1)** that secures each hard drive to the computer.
4. Disconnect the hard drives **(2)** from the system board by sliding the hard drives away from the hard drive connectors.

5. Remove the hard drives **(3)** from the hard drive compartments.

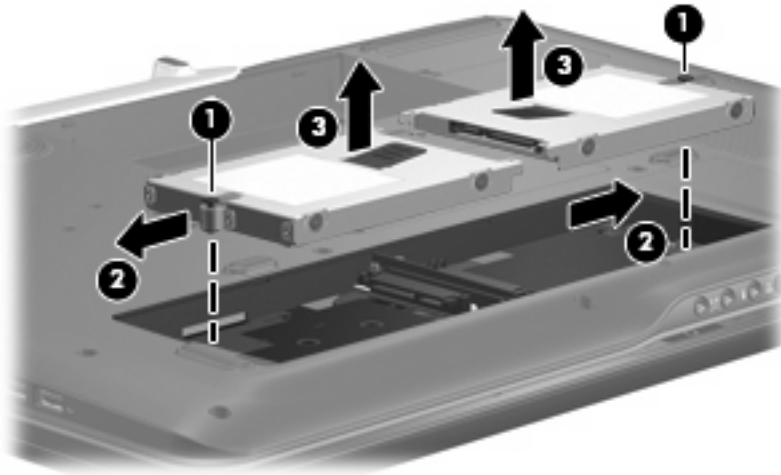

6. If it is necessary to replace the hard drive bracket, remove the four Phillips PM3.0x4.0 screws **(1)** that secure the hard drive bracket to the hard drive.
7. Lift the bracket **(2)** straight up to remove it from the hard drive.

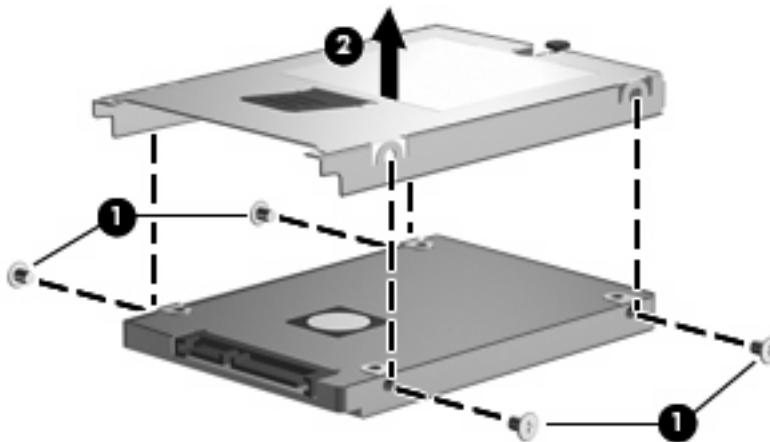

Reverse this procedure to reassemble and install the hard drive.

# WLAN module

Description	Spare part number
<b>Intel 802.11a/b/g/n WLAN modules:</b>	
<ul style="list-style-type: none"><li>For use in Antigua &amp; Barbuda, Argentina, Aruba, the Bahamas, Barbados, Bermuda, Brunei, Canada, the Cayman Islands, Chile, Colombia, Costa Rica, the Dominican Republic, Ecuador, El Salvador, Guam, Guatemala, Haiti, Honduras, Hong Kong, India, Indonesia, Malaysia, Mexico, Panama, Paraguay, Peru, Saudi Arabia, Taiwan, Uruguay, the United States, Venezuela, and Vietnam</li></ul>	441086-001
<ul style="list-style-type: none"><li>For use in Austria, Azerbaijan, Bahrain, Belgium, Brazil, Bulgaria, Croatia, Cyprus, the Czech Republic, Denmark, Egypt, Estonia, Finland, France, Georgia, Germany, Greece, Hungary, Iceland, Ireland, Israel, Italy, Latvia, Lebanon, Liechtenstein, Lithuania, Luxembourg, Malta, Monaco, the Netherlands, Norway, Oman, the Philippines, Poland, Portugal, Qatar, Romania, Russia, Serbia and Montenegro, Singapore, Slovakia, Slovenia, South Africa, Spain, Sri Lanka, Sweden, Switzerland, Turkey, Ukraine, the United Kingdom, and Uzbekistan</li></ul>	441086-002
<ul style="list-style-type: none"><li>For use in Australia, New Zealand, Pakistan, the People's Republic of China, and South Korea</li></ul>	441086-003
<b>Intel 802.11a/b/g WLAN modules:</b>	
<ul style="list-style-type: none"><li>For use in Antigua &amp; Barbuda, Argentina, Aruba, the Bahamas, Barbados, Bermuda, Brunei, Canada, the Cayman Islands, Chile, Colombia, Costa Rica, the Dominican Republic, Ecuador, El Salvador, Guam, Guatemala, Haiti, Honduras, Hong Kong, India, Indonesia, Malaysia, Mexico, Panama, Paraguay, Peru, Saudi Arabia, Taiwan, Uruguay, the United States, Venezuela, and Vietnam</li></ul>	452063-001
<ul style="list-style-type: none"><li>For use in Austria, Azerbaijan, Bahrain, Belgium, Brazil, Bulgaria, Croatia, Cyprus, the Czech Republic, Denmark, Egypt, Estonia, Finland, France, Georgia, Germany, Greece, Hungary, Iceland, Ireland, Israel, Italy, Latvia, Lebanon, Liechtenstein, Lithuania, Luxembourg, Malta, Monaco, the Netherlands, Norway, Oman, the Philippines, Poland, Portugal, Qatar, Romania, Russia, Serbia and Montenegro, Singapore, Slovakia, Slovenia, South Africa, Spain, Sri Lanka, Sweden, Switzerland, Turkey, Ukraine, the United Kingdom, and Uzbekistan</li></ul>	452063-002
<ul style="list-style-type: none"><li>For use in Australia, New Zealand, Pakistan, the People's Republic of China, and South Korea</li></ul>	452063-003

Before removing the WLAN module, follow these steps:

1. Shut down the computer. If you are unsure whether the computer is off or in Hibernation, turn the computer on, and then shut it down through the operating system.
2. Disconnect all external devices connected to the computer.
3. Disconnect the power from the computer by first unplugging the power cord from the AC outlet and then unplugging the AC adapter from the computer.
4. Remove the battery (see [Battery on page 38](#)).

Remove the WLAN module:

1. Position the computer with the front toward you.
2. Loosen the Phillips PM2.0×5.0 screw **(1)** that secures the WLAN module compartment cover to the computer.

3. Lift the right side of the WLAN module compartment cover **(2)**, swing the cover up and to the left, and remove the cover. The WLAN module compartment cover is included in the Plastics Kit, spare part number 448171-001.

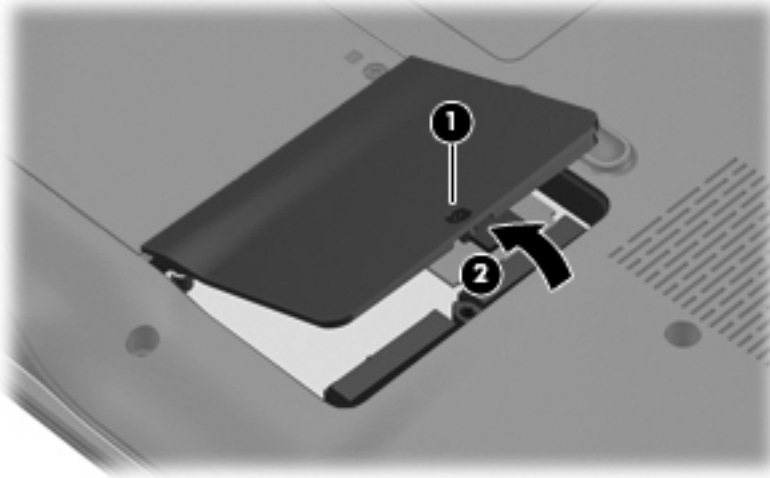

4. Disconnect the WLAN antenna cables **(1)** from the WLAN module.

 **NOTE:** The main WLAN antenna cable (labeled with the number 1 or with a black band) is connected to the WLAN module “Main” terminal. The white WLAN antenna cable (labeled with the number 2 or with a white band) is connected to the WLAN module “Aux” terminal. Computer models equipped with an 802.11a/b/g/n WLAN module will have an additional wireless antenna cable **(2)** (labeled with the number 3 or with a yellow band). Disconnect this cable.

5. Remove the two Phillips PM2.5×5.0 screws **(3)** that secure the WLAN module to the system board. (The edge of the module opposite the slot rises away from the computer.)
6. Remove the WLAN module **(4)** by pulling it away from the slot at an angle.

 **NOTE:** WLAN modules are designed with a notch **(5)** to prevent incorrect installation into the WLAN module slot.

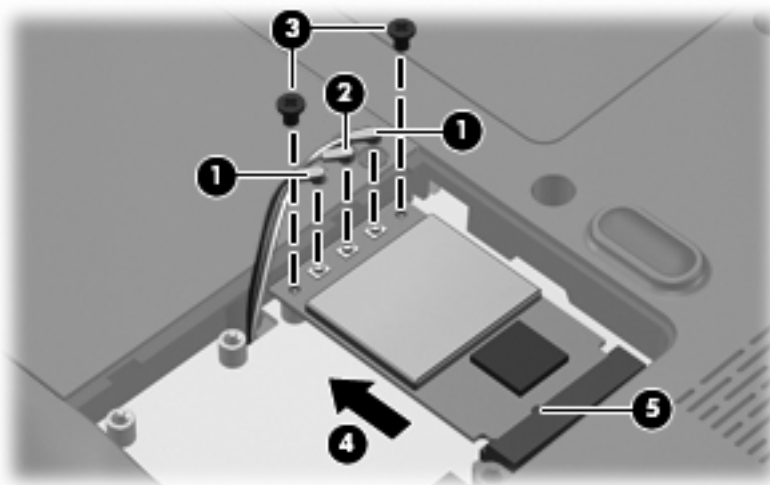

Reverse this procedure to install a WLAN module.



## TV tuner module

Description	Spare part number
For use only in Europe, the Middle East, and Africa	448168-002
For use only in North America	448168-001

Before removing the TV tuner module, follow these steps:

1. Shut down the computer. If you are unsure whether the computer is off or in Hibernation, turn the computer on, and then shut it down through the operating system.
2. Disconnect all external devices connected to the computer.
3. Disconnect the power from the computer by first unplugging the power cord from the AC outlet and then unplugging the AC adapter from the computer.
4. Remove the battery (see [Battery on page 38](#)).

Remove the TV tuner module:

1. Position the computer with the front toward you.
2. Loosen the two black Phillips PM2.0×5.0 captive screws **(1)** that secure the TV tuner module compartment cover to the computer.
3. Lift the left side of the TV tuner module compartment cover **(2)**, swing the cover up and to the right, and remove the cover. The TV tuner module compartment cover is included in the Plastics Kit, spare part number 448171-001.

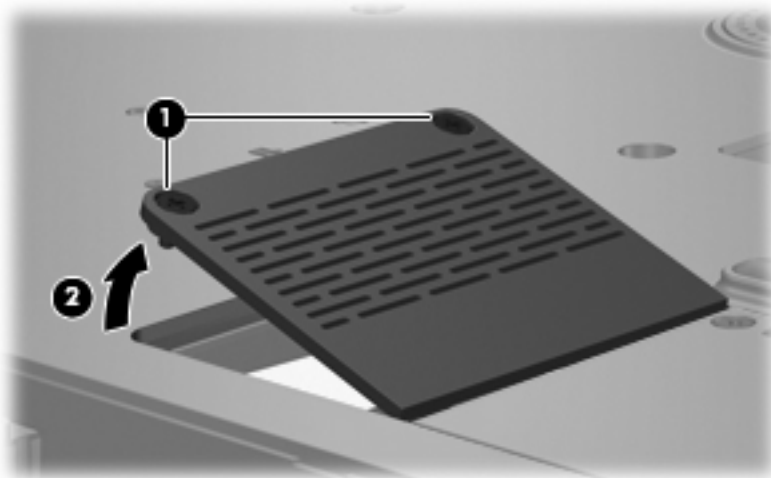

4. Disconnect the TV tuner cable **(1)** from the TV tuner module.
5. Remove the two Phillips PM2.5×5.0 screws **(2)** that secure the TV tuner module to the system board. (The edge of the module opposite the slot rises away from the computer.)

6. Remove the TV tuner module **(3)** by pulling it away from the slot at an angle.

 **NOTE:** The TV tuner module is designed with a notch **(4)** to prevent incorrect installation into the TV tuner module slot.

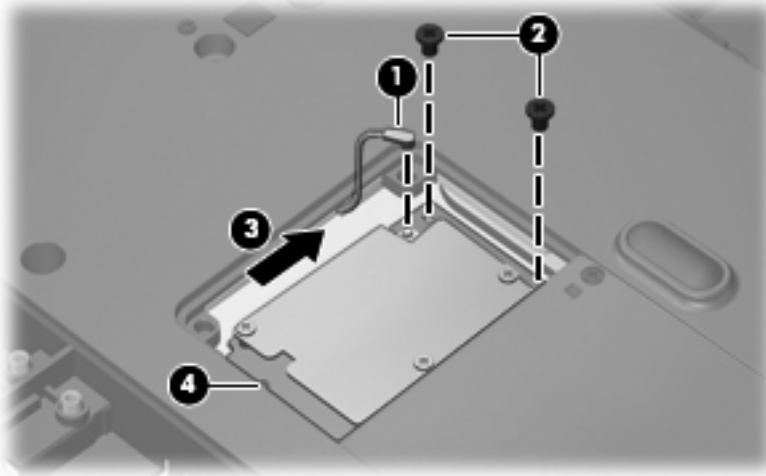

Reverse this procedure to install the TV tuner module.

## Memory module

Description	Spare part number
2048-MB (667-MHz, PC2-5300, 1-DIMM)	448151-001
1024-MB (667-MHz, PC2-5300, 1-DIMM)	448150-001
512-MB (667-MHz, PC2-5300, 1-DIMM)	452312-001

Before removing the memory module, follow these steps:

1. Shut down the computer. If you are unsure whether the computer is off or in Hibernation, turn the computer on, and then shut it down through the operating system.
2. Disconnect all external devices connected to the computer.
3. Disconnect the power from the computer by first unplugging the power cord from the AC outlet and then unplugging the AC adapter from the computer.
4. Remove the battery (see [Battery on page 38](#)).

Remove the memory module:

1. Position the computer with the front toward you.
2. Loosen the two black Phillips PM2.0×5.0 captive screws **(1)** that secure the memory module compartment cover to the computer.

3. Lift the rear edge of the cover **(2)**, swing it forward, and remove the cover. The memory module compartment cover is included in the Plastics Kit, spare part number 448171-001.

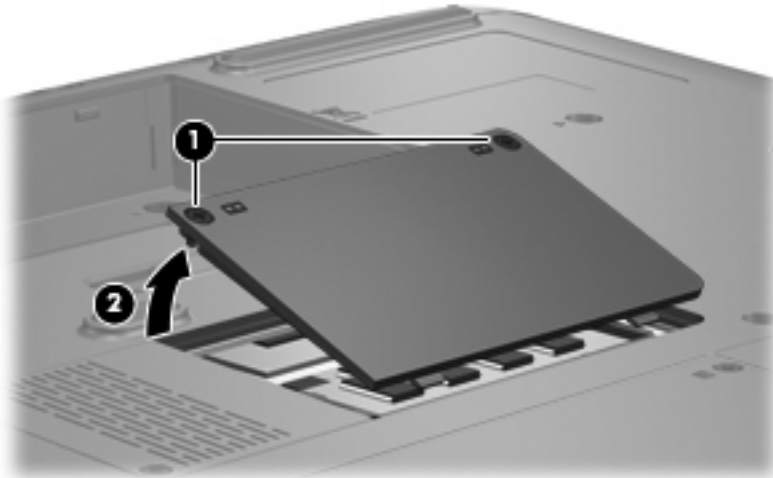

4. Spread the retaining tabs **(1)** on each side of the memory module slot to release the memory module. (The edge of the module opposite the slot rises away from the computer.)
5. Remove the module **(2)** by pulling it away from the slot at an angle.

 **NOTE:** Memory modules are designed with a notch **(3)** to prevent incorrect installation into the memory module slot.

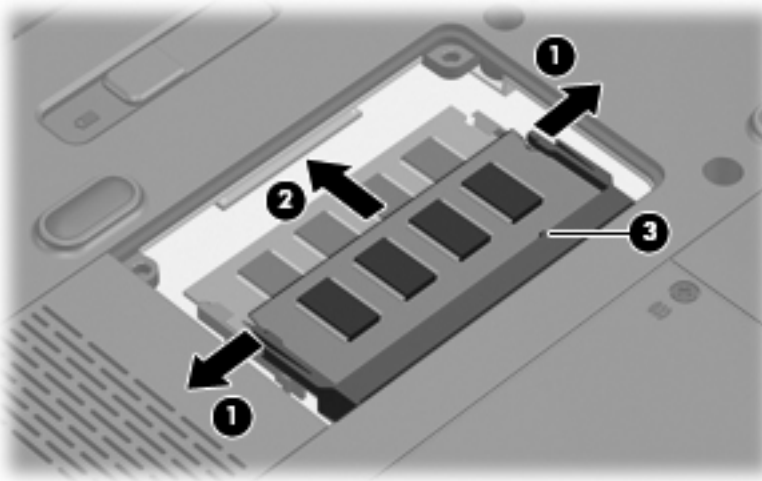

Reverse this procedure to install a memory module.

## Optical drive

 **NOTE:** All optical drive spare part kits include an optical drive bezel and bracket.

Description	Spare part number
HD-DVD	448156-001
DVD±RW and CD-RW Super Multi Double-Layer Combo Drive with LightScribe	448157-001

Before removing the optical drive, follow these steps:

1. Shut down the computer. If you are unsure whether the computer is off or in Hibernation, turn the computer on, and then shut it down through the operating system.
2. Disconnect all external devices connected to the computer.
3. Disconnect the power from the computer by first unplugging the power cord from the AC outlet and then unplugging the AC adapter from the computer.
4. Remove the battery (see [Battery on page 38](#)).

Remove the optical drive:

1. Position the computer with right side toward you.
2. Remove the Phillips PM2.5×8.0 screw **(1)** that secures the optical drive to the computer.
3. Insert a flat-bladed screwdriver or similar tool into the optical drive tab access **(2)** and press the tab to the left to release the optical drive from the computer.
4. Remove the optical drive **(3)**.

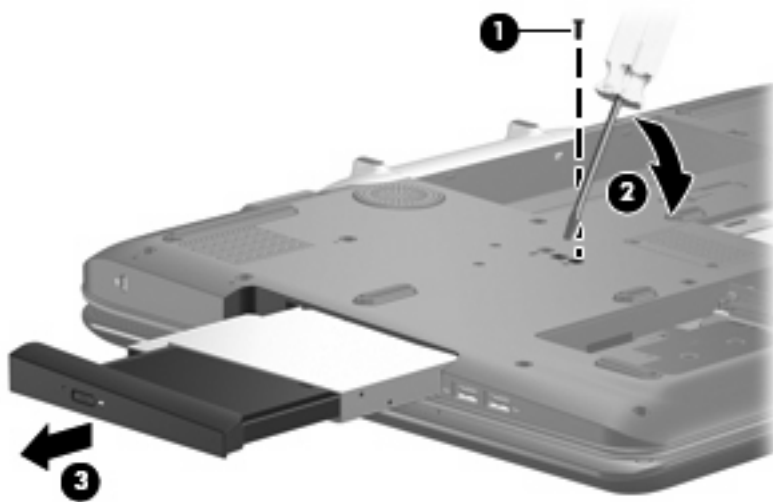

5. If it is necessary to replace the optical drive bracket, position the optical drive with the optical drive bracket toward you.
6. Remove the two Phillips PM2.0×3.0 screws **(1)** that secure the optical drive bracket to the optical drive.

7. Remove the optical drive bracket **(2)**.

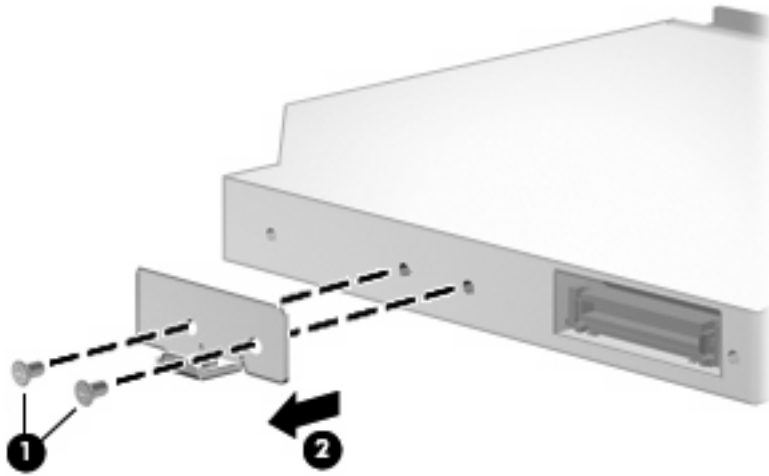

Reverse the above procedure to reassemble and install the optical drive.

# Keyboard

Description			
For use in:	Spare part number	For use in:	Spare part number
Denmark, Finland, Norway, and Sweden	448159-DH1	Latin America	448159-161
France	448159-051	South Korea	448159-AD1
French Canada	448159-121	Spain	448159-071
Germany	448159-041	The United Kingdom	448159-031
The Netherlands and Europe	448159-B31	The United States	448159-001
Italy	448159-061		

Before removing the keyboard, follow these steps:

1. Shut down the computer. If you are unsure whether the computer is off or in Hibernation, turn the computer on, and then shut it down through the operating system.
2. Disconnect all external devices connected to the computer.
3. Disconnect the power from the computer by first unplugging the power cord from the AC outlet and then unplugging the AC adapter from the computer.
4. Remove the battery (see [Battery on page 38](#)).
5. Remove the hard drives (see [Hard drive on page 45](#)).

Remove the keyboard:

1. Position the computer with the front toward you.
2. Remove the three Phillips PM2.5×8.0 screws **(1)** and the four Phillips PM2.5×5.0 screws **(2)** that secure the keyboard to the computer.

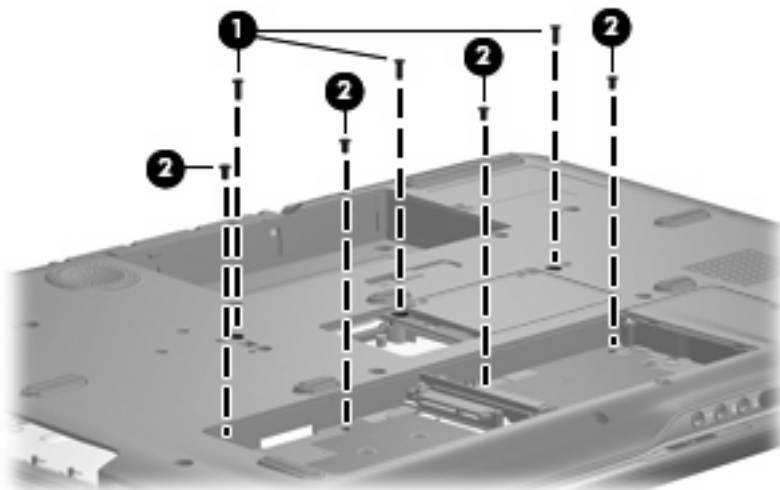

3. Turn the computer display-side up, with the front toward you.

4. Open the computer as far as possible.
5. Lift the front edge of the keyboard **(1)** until it rests at an angle.
6. Slide the keyboard **(2)** forward until the tabs on the rear edge of the keyboard disengage from the slots in the top cover.
7. Rotate the rear edge of the keyboard **(3)** forward until it rests upside down on the palm rest.

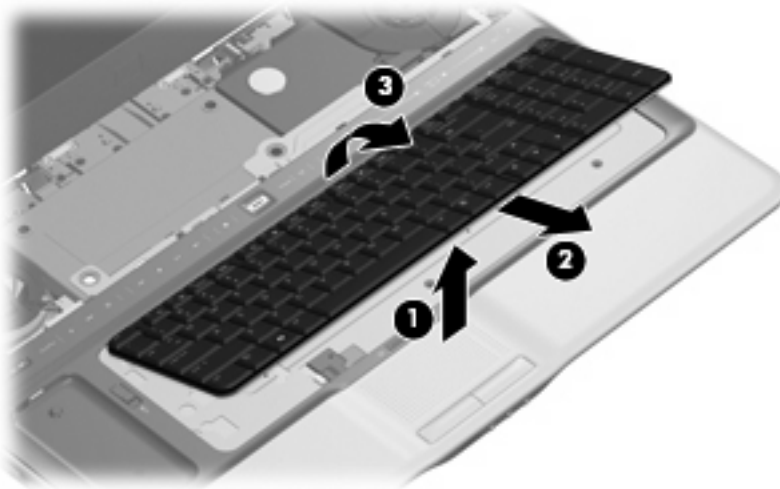

8. Release the zero insertion force (ZIF) connector **(1)** to which the keyboard cable is attached and disconnect the keyboard cable **(2)**.

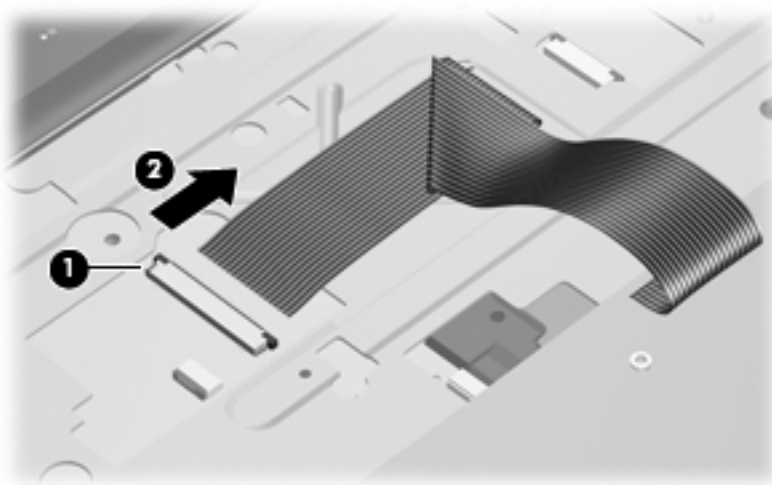

9. Remove the keyboard.

Reverse this procedure to install the keyboard.

## Hinge cover

Description	Spare part number
Hinge cover	452311-001

Before removing the hinge cover, follow these steps:

1. Shut down the computer. If you are unsure whether the computer is off or in Hibernation, turn the computer on, and then shut it down through the operating system.
2. Disconnect all external devices connected to the computer.
3. Disconnect the power from the computer by first unplugging the power cord from the AC outlet and then unplugging the AC adapter from the computer.
4. Remove the battery (see [Battery on page 38](#)).

Remove the hinge cover:

1. Position the computer with the rear panel toward you.
2. Remove the four gray rubber screw covers **(1)** and **(2)** from the hinge cover. The screw covers come in two different sizes and are available in the Rubber Feet Kit, spare part number 452320-001.
3. Remove the four Phillips PM3.0×8.0 screws **(3)** that secure the hinge cover to the computer.
4. Remove the hinge cover **(4)** by pulling it away from the computer.

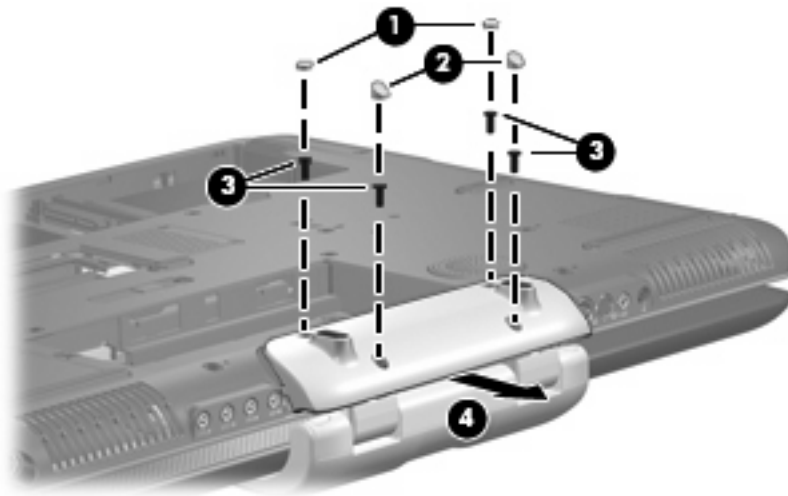

Reverse this procedure to install the hinge cover.



## Rear cover

Description	Spare part number
Rear cover	448161-001

Before removing the rear cover, follow these steps:

1. Shut down the computer. If you are unsure whether the computer is off or in Hibernation, turn the computer on, and then shut it down through the operating system.
2. Disconnect all external devices connected to the computer.
3. Disconnect the power from the computer by first unplugging the power cord from the AC outlet and then unplugging the AC adapter from the computer.
4. Remove the battery (see [Battery on page 38](#)).
5. Remove the hinge cover (see [Hinge cover on page 56](#)).

Remove the rear cover:

1. Position the computer with the front toward you.
2. Remove the seven Phillips PM2.5×8.0 screws **(1)** that secure the rear cover to the computer.
3. Remove the Mylar screw cover **(2)** in the optical drive bay. This screw cover is available in the Rubber Feet Kit, spare part number 452320-001.
4. Remove the Phillips PM2.5×4.0 screw **(3)** that secures the rear cover to the computer.

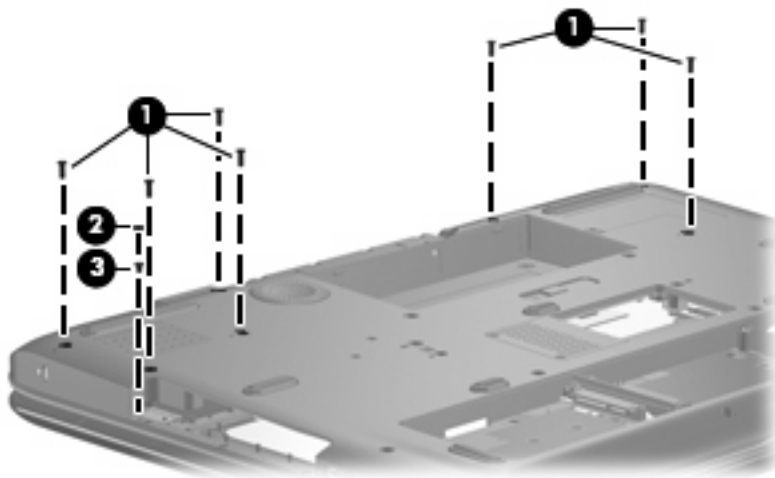

5. Remove the four Phillips PM3.0×12.0 screws **(1)** that secure the rear cover to the computer.

6. Remove the four Phillips PM2.5×4.0 broad-head screws **(2)** that secure the rear cover to the computer.

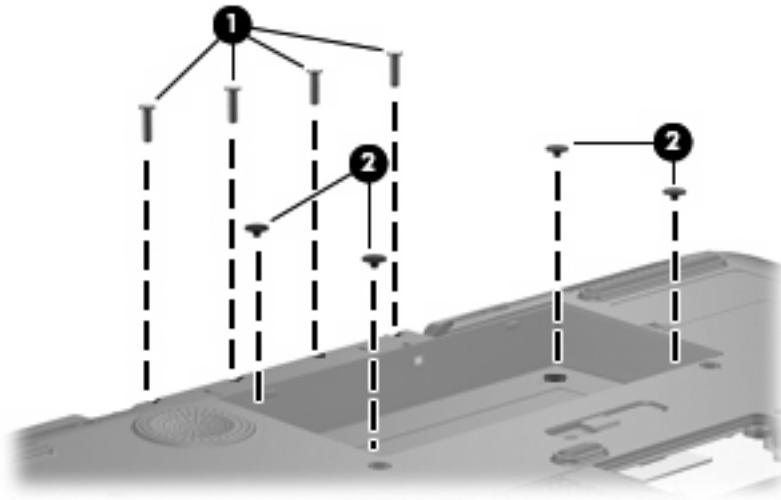

7. Turn the computer right-side up, with the front toward you.
8. Open the computer as far as possible.
9. Remove the rear cover.

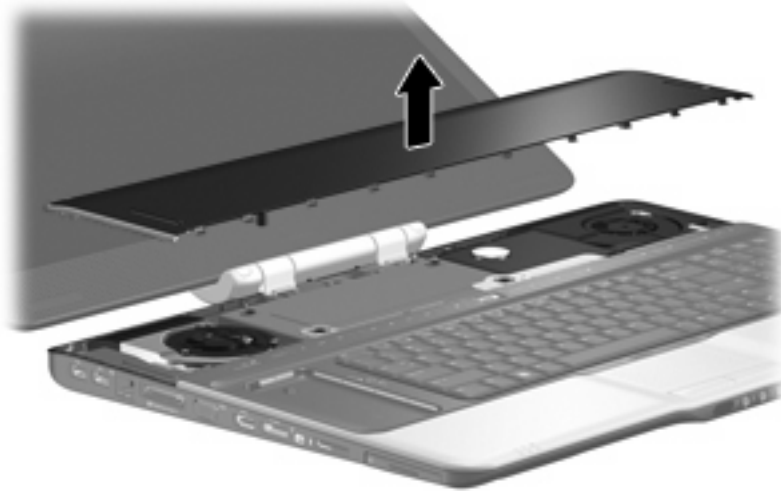

Reverse this procedure to install the rear cover.

## Top cover

Description	Spare part number
Top cover (includes TouchPad board cable and TouchPad button cable, and LED boards and cables)	448174-001

Before removing the top cover, follow these steps:

1. Shut down the computer. If you are unsure whether the computer is off or in Hibernation, turn the computer on, and then shut it down through the operating system.
2. Disconnect all external devices connected to the computer.
3. Disconnect the power from the computer by first unplugging the power cord from the AC outlet and then unplugging the AC adapter from the computer.
4. Remove the battery (see [Battery on page 38](#)).
5. Remove the following components:
  - a. Hard drive (see [Hard drive on page 45](#))
  - b. Optical drive (see [Optical drive on page 52](#))
  - c. Keyboard (see [Keyboard on page 54](#))
  - d. Hinge cover (see [Hinge cover on page 56](#))
  - e. Rear cover (see [Rear cover on page 57](#))

Remove the top cover:

1. Turn the computer upside down, with the front toward you.
2. Remove the two Mylar screw covers (**1**) in the optical drive bay. These screw covers are available in the Rubber Feet Kit, spare part number 452320-001.
3. Remove the two Phillips PM2.5×4.0 screws (**2**) and the ten Phillips PM2.5×8.0 screws (**3**) that secure the top cover to the computer.

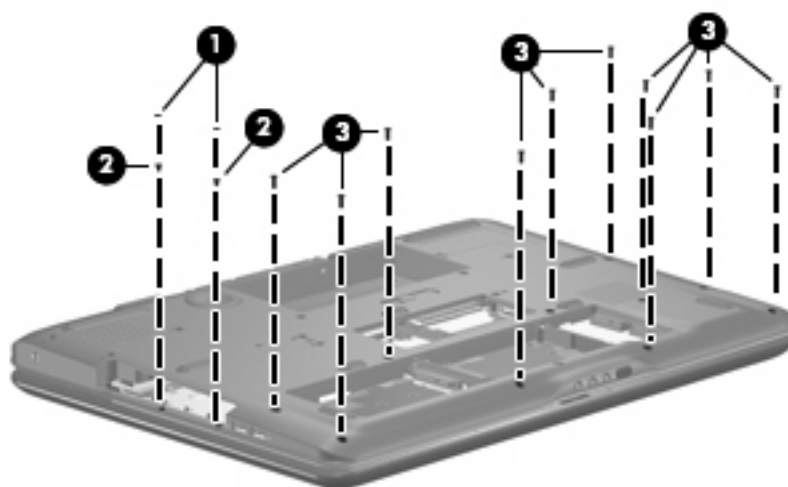

4. Remove the four Phillips PM2.5×5.0 screws **(1)** and the two Phillips PM2.5×11.0 screws **(2)** that secure the top cover to the computer.

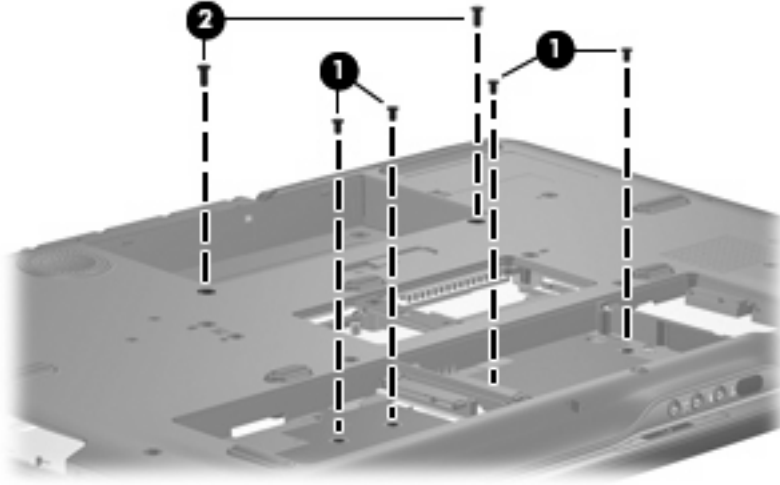

5. Turn the computer right-side up, with the front toward you.
6. Open the computer as far as possible.
7. Disconnect the following cables:
  - (1)** Fingerprint reader board cable
  - (2)** LED board cable
  - (3)** TouchPad board cable
  - (4)** TouchPad on/off board cable

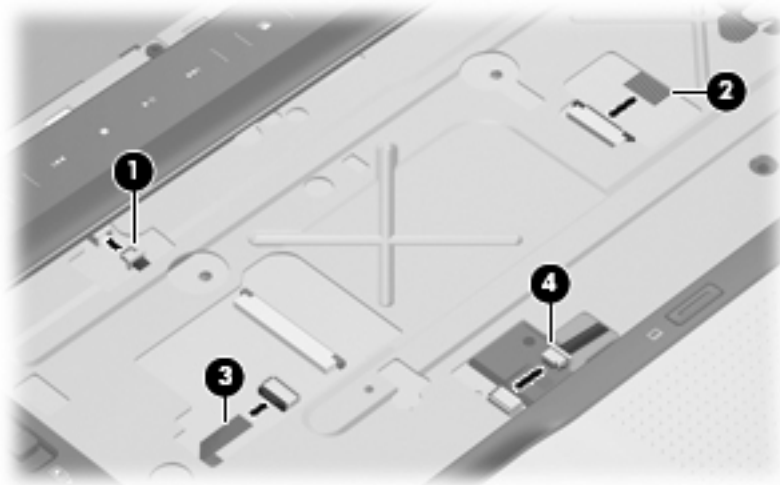

8. Remove the two Phillips PM2.5×5.0 screws **(1)** that secure the top cover to the computer.

9. Lift the rear edge of the top cover **(2)** until the top cover disengages from the computer.

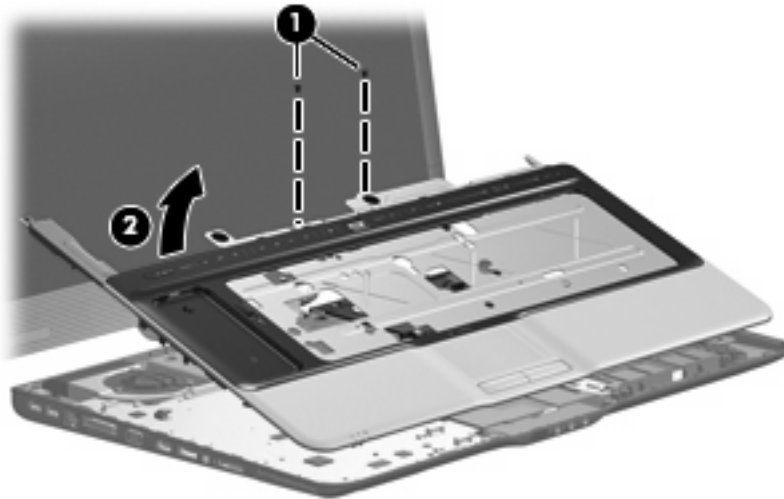

10. Remove the top cover.

Reverse this procedure to install the top cover.

## Fingerprint reader board

Description	Spare part number
Fingerprint reader board (includes cable)	448166-001

Before removing the fingerprint reader board, follow these steps:

1. Shut down the computer. If you are unsure whether the computer is off or in Hibernation, turn the computer on, and then shut it down through the operating system.
2. Disconnect all external devices connected to the computer.
3. Disconnect the power from the computer by first unplugging the power cord from the AC outlet and then unplugging the AC adapter from the computer.
4. Remove the battery (see [Battery on page 38](#)).
5. Remove the following components:
  - a. Hard drive (see [Hard drive on page 45](#))
  - b. Optical drive (see [Optical drive on page 52](#))
  - c. Keyboard (see [Keyboard on page 54](#))
  - d. Hinge cover (see [Hinge cover on page 56](#))
  - e. Rear cover (see [Rear cover on page 57](#))
  - f. Top cover (see [Top cover on page 59](#))

Remove the fingerprint reader board:

1. Turn the top cover upside down, with the front toward you.
2. Remove the two silver Phillips PM2.0×4.0 screws **(1)** that secure the fingerprint reader board and bracket to the top cover.
3. Remove the fingerprint reader board bracket **(2)** and fingerprint reader board **(3)**.

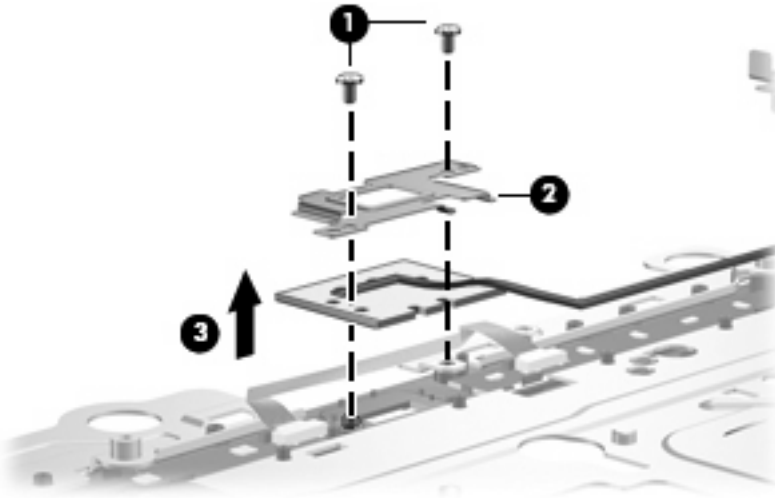

Reverse this procedure to install the fingerprint reader board.

## TouchPad on/off board

Description	Spare part number
TouchPad on/off board (includes cable)	448167-001

Before removing the TouchPad on/off board, follow these steps:

1. Shut down the computer. If you are unsure whether the computer is off or in Hibernation, turn the computer on, and then shut it down through the operating system.
2. Disconnect all external devices connected to the computer.
3. Disconnect the power from the computer by first unplugging the power cord from the AC outlet and then unplugging the AC adapter from the computer.
4. Remove the battery (see [Battery on page 38](#)).
5. Remove the following components:
  - a. Hard drive (see [Hard drive on page 45](#))
  - b. Optical drive (see [Optical drive on page 52](#))
  - c. Keyboard (see [Keyboard on page 54](#))
  - d. Hinge cover (see [Hinge cover on page 56](#))

- e. Rear cover (see [Rear cover on page 57](#))
- f. Top cover (see [Top cover on page 59](#))

Remove the TouchPad on/off board:

1. Turn the top cover upside down, with the front toward you.
2. Remove the two silver Phillips PM2.0×4.0 screws **(1)** that secure the TouchPad on/off board to the top cover.
3. Remove the TouchPad on/off board **(2)**.

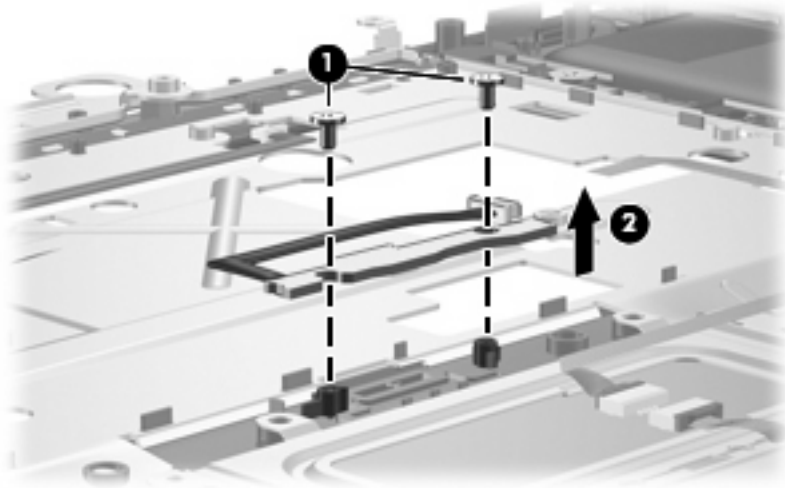

Reverse this procedure to install the TouchPad on/off board.

## Display assembly

Description	Spare part number
20.1-inch, WSXGA BrightView display assembly (includes camera module and cable, microphones, speakers, and WLAN antennae)	452299-001
20.1-inch, WUXGA BrightView display assembly (includes camera module and cable, microphones, speakers, and WLAN antennae)	452300-001

Before removing the display assembly, follow these steps:

1. Shut down the computer. If you are unsure whether the computer is off or in Hibernation, turn the computer on, and then shut it down through the operating system.
2. Disconnect all external devices connected to the computer.
3. Disconnect the power from the computer by first unplugging the power cord from the AC outlet and then unplugging the AC adapter from the computer.
4. Remove the battery (see [Battery on page 38](#)).
5. Disconnect the WLAN module antenna cables from the WLAN module (see [WLAN module on page 47](#)).
6. Remove the following components:
  - a. Hard drive (see [Hard drive on page 45](#))
  - b. Optical drive (see [Optical drive on page 52](#))
  - c. Keyboard (see [Keyboard on page 54](#))
  - d. Hinge cover (see [Hinge cover on page 56](#))
  - e. Rear cover (see [Rear cover on page 57](#))
  - f. Top cover (see [Top cover on page 59](#))

Remove the display assembly:

1. Close the computer and turn it upside down, with the front toward you.



2. Remove the six Phillips PM3.0×8.0 screws that secure the display assembly to the computer.

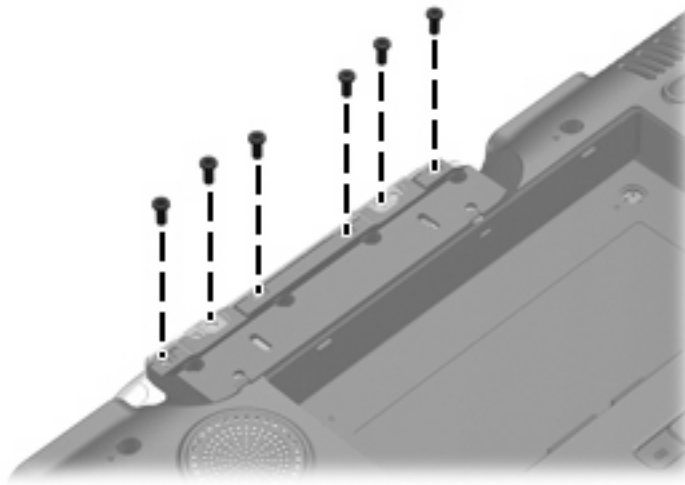

3. Turn the computer display-side up, with the front toward you.
4. Open the computer to an upright position.
5. Disconnect the following cable connectors:
  - (1) Display panel cable
  - (2) Camera module cable
  - (3) Speaker cable
  - (4) Microphone cable

---

 **NOTE:** The speaker cables are black and red and share a single connector. The microphone cables are gray and white and share a single connector. Be sure that these connectors are correctly reconnected when installing the display assembly.

---

6. Remove the WLAN antenna cables **(5)** from the opening in the system board.

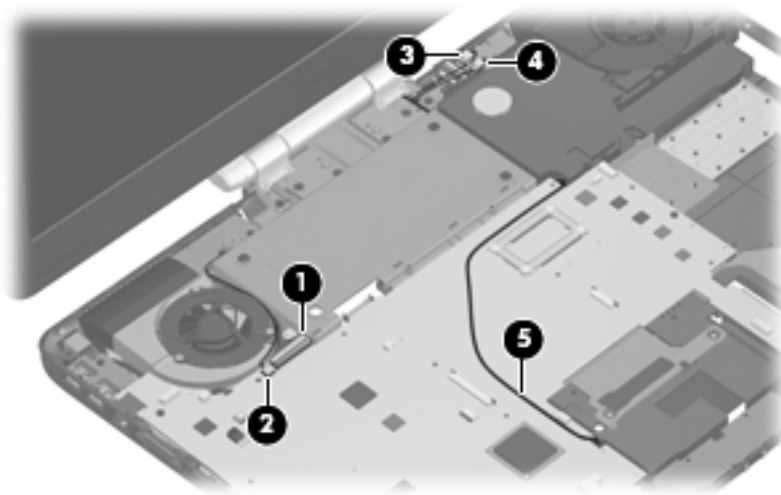

△ **CAUTION:** The display assembly will be unsupported when the following screws are removed. To prevent damage to the display assembly, support the display assembly before removing the screws.

7. Remove the six Phillips PM3.0×8.0 screws **(1)** that secure the display assembly to the computer.
8. Remove the display assembly **(2)**.

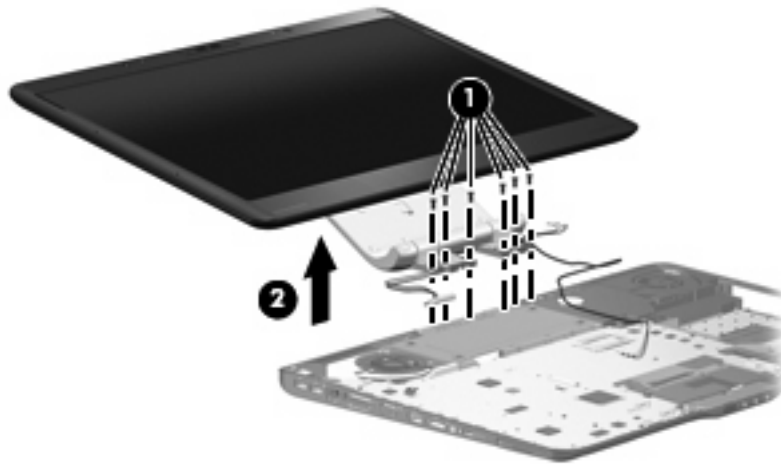

📄 **NOTE:** If it is necessary to replace any of the display assembly internal components, see [Display assembly internal components on page 40](#) for display bezel removal information.

Reverse this procedure to install the display assembly.

## Audio/infrared board

Description	Spare part number
Audio/infrared board	452316-001

Before removing the audio/infrared board, follow these steps:

1. Shut down the computer. If you are unsure whether the computer is off or in Hibernation, turn the computer on, and then shut it down through the operating system.
2. Disconnect all external devices connected to the computer.
3. Disconnect the power from the computer by first unplugging the power cord from the AC outlet and then unplugging the AC adapter from the computer.
4. Remove the battery (see [Battery on page 38](#)).
5. Remove the following components:
  - a. Hard drive (see [Hard drive on page 45](#))
  - b. Optical drive (see [Optical drive on page 52](#))
  - c. Keyboard (see [Keyboard on page 54](#))
  - d. Hinge cover (see [Hinge cover on page 56](#))
  - e. Rear cover (see [Rear cover on page 57](#))
  - f. Top cover (see [Top cover on page 59](#))

Remove the audio/infrared board:

1. Disconnect the audio/infrared board cable **(1)** from the system board.
2. Remove the two Phillips PM2.5×5.0 screws **(2)** that secure the audio/infrared board to the computer.
3. Remove the audio/infrared board **(3)** from the base enclosure.

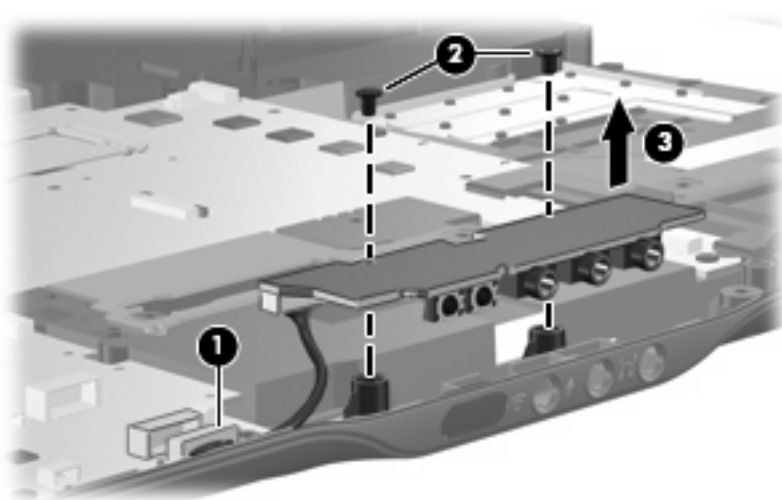

Reverse this procedure to install the audio/infrared board.

## Bluetooth module

 **NOTE:** The Bluetooth module spare part kit does not include a Bluetooth module cable. The Bluetooth module cable is available in the Cable Kit, spare part number 448169-001.

Description	Spare part number
Bluetooth module	398393-002

Before removing the Bluetooth module, follow these steps:

1. Shut down the computer. If you are unsure whether the computer is off or in Hibernation, turn the computer on, and then shut it down through the operating system.
2. Disconnect all external devices connected to the computer.
3. Disconnect the power from the computer by first unplugging the power cord from the AC outlet and then unplugging the AC adapter from the computer.
4. Remove the battery (see [Battery on page 38](#)).
5. Remove the following components:
  - a. Hard drive (see [Hard drive on page 45](#))
  - b. Optical drive (see [Optical drive on page 52](#))
  - c. Keyboard (see [Keyboard on page 54](#))
  - d. Hinge cover (see [Hinge cover on page 56](#))
  - e. Rear cover (see [Rear cover on page 57](#))
  - f. Top cover (see [Top cover on page 59](#))

Remove the Bluetooth module:

1. Disconnect the Bluetooth module cable **(1)** from the system board.
2. Remove the two silver Phillips PM2.0×4.0 screws **(2)** that secure the Bluetooth module to the computer.

3. Remove the Bluetooth module **(3)** from the base enclosure.

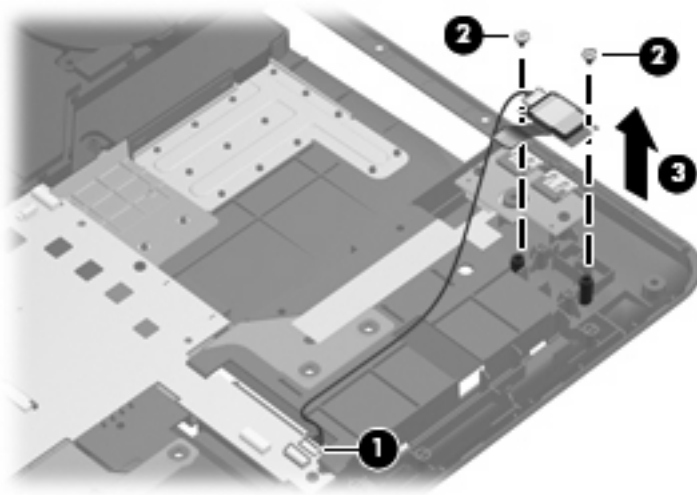

Reverse this procedure to install the Bluetooth module.

## Front USB board

Description	Spare part number
Front USB board	452314-001

Before removing the front USB board, follow these steps:

1. Shut down the computer. If you are unsure whether the computer is off or in Hibernation, turn the computer on, and then shut it down through the operating system.
2. Disconnect all external devices connected to the computer.
3. Disconnect the power from the computer by first unplugging the power cord from the AC outlet and then unplugging the AC adapter from the computer.
4. Remove the battery (see [Battery on page 38](#)).
5. Remove the following components:
  - a. Hard drive (see [Hard drive on page 45](#))
  - b. Optical drive (see [Optical drive on page 52](#))
  - c. Keyboard (see [Keyboard on page 54](#))
  - d. Hinge cover (see [Hinge cover on page 56](#))
  - e. Rear cover (see [Rear cover on page 57](#))
  - f. Top cover (see [Top cover on page 59](#))

Remove the front USB board:

1. Disconnect the front USB board cable **(1)** from the system board.
2. Remove the two Phillips PM2.5×4.0 screws **(2)** that secure front USB board the to the computer.
3. Remove the front USB board **(3)**.

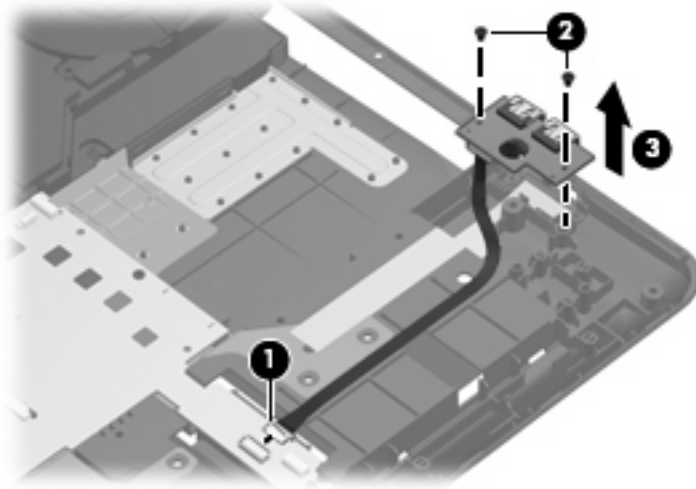

Reverse this procedure to install the front USB board.

## Power connector LED board

Description	Spare part number
Power connector LED board (includes cable)	452318-001

Before removing the power connector LED board, follow these steps:

1. Shut down the computer. If you are unsure whether the computer is off or in Hibernation, turn the computer on, and then shut it down through the operating system.
2. Disconnect all external devices connected to the computer.
3. Disconnect the power from the computer by first unplugging the power cord from the AC outlet and then unplugging the AC adapter from the computer.
4. Remove the battery (see [Battery on page 38](#)).
5. Remove the following components:
  - a. Hard drive (see [Hard drive on page 45](#))
  - b. Optical drive (see [Optical drive on page 52](#))
  - c. Keyboard (see [Keyboard on page 54](#))
  - d. Hinge cover (see [Hinge cover on page 56](#))

- e. Rear cover (see [Rear cover on page 57](#))
- f. Top cover (see [Top cover on page 59](#))

Remove the power connector LED board:

1. Disconnect the power connector LED board **(1)** from the system board.
2. Remove the power connector LED board **(2)**.

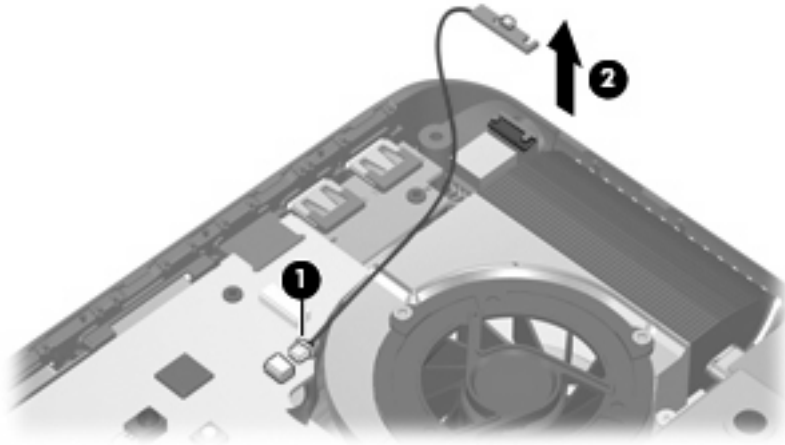

Reverse this procedure to install the power connector LED board.

## Rear USB board

Description	Spare part number
Rear USB board (includes cable)	452315-001

Before removing the rear USB board, follow these steps:

1. Shut down the computer. If you are unsure whether the computer is off or in Hibernation, turn the computer on, and then shut it down through the operating system.
2. Disconnect all external devices connected to the computer.
3. Disconnect the power from the computer by first unplugging the power cord from the AC outlet and then unplugging the AC adapter from the computer.
4. Remove the battery (see [Battery on page 38](#)).
5. Remove the following components:
  - a. Hard drive (see [Hard drive on page 45](#))
  - b. Optical drive (see [Optical drive on page 52](#))
  - c. Keyboard (see [Keyboard on page 54](#))
  - d. Hinge cover (see [Hinge cover on page 56](#))

- e. Rear cover (see [Rear cover on page 57](#))
- f. Top cover (see [Top cover on page 59](#))

Remove the rear USB board:

1. Disconnect the rear USB board cable **(1)** from the system board.
2. Remove the Phillips PM2.5×4.0 screw **(2)** that secures rear USB board the to the computer.
3. Remove the rear USB board **(3)**.

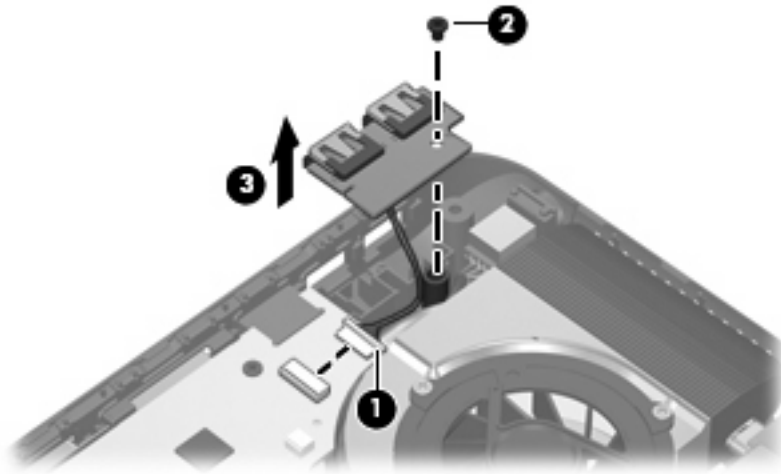

Reverse this procedure to install the rear USB board.

## Subwoofer

Description	Spare part number
Subwoofer (includes rubber isolators)	448164-001

Before removing the subwoofer, follow these steps:

1. Shut down the computer. If you are unsure whether the computer is off or in Hibernation, turn the computer on, and then shut it down through the operating system.
2. Disconnect all external devices connected to the computer.
3. Disconnect the power from the computer by first unplugging the power cord from the AC outlet and then unplugging the AC adapter from the computer.
4. Remove the battery (see [Battery on page 38](#)).
5. Remove the following components:
  - a. Hard drive (see [Hard drive on page 45](#))
  - b. Optical drive (see [Optical drive on page 52](#))
  - c. Keyboard (see [Keyboard on page 54](#))



- d. Hinge cover (see [Hinge cover on page 56](#))
- e. Rear cover (see [Rear cover on page 57](#))
- f. Top cover (see [Top cover on page 59](#))

Remove the subwoofer:

1. Disconnect the subwoofer cable **(1)** from the system board.
2. Remove the three Phillips PM2.5×8.0 screws **(2)** that secure subwoofer to the base enclosure.
3. Remove the subwoofer **(3)**.

△ **CAUTION:** When installing the subwoofer, do not overtighten the screws. Overtightening the subwoofer screws can result in damage to the subwoofer grommets **(4)**, which can cause a decrease in the subwoofer performance.

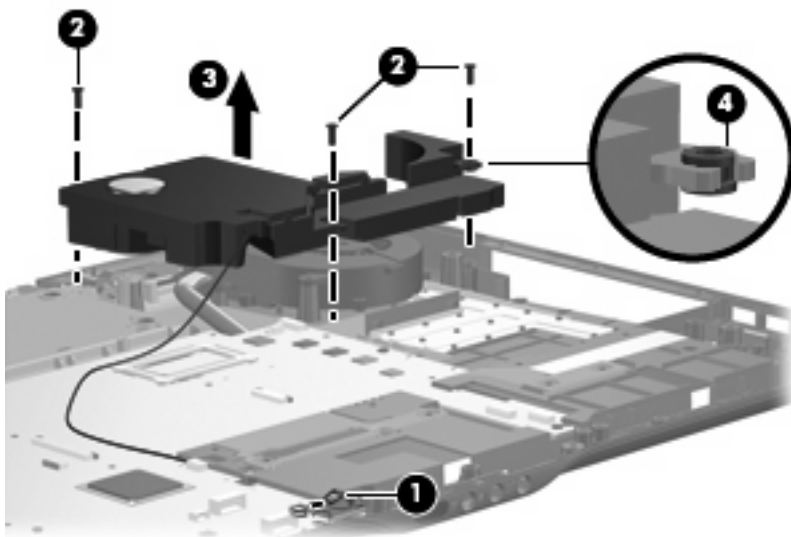

Reverse this procedure to install the subwoofer.

## Video connector board

Description	Spare part number
Video connector board (includes cable)	452321-001

Before removing the audio connector board, follow these steps:

1. Shut down the computer. If you are unsure whether the computer is off or in Hibernation, turn the computer on, and then shut it down through the operating system.
2. Disconnect all external devices connected to the computer.
3. Disconnect the power from the computer by first unplugging the power cord from the AC outlet and then unplugging the AC adapter from the computer.

4. Remove the battery (see [Battery on page 38](#)).
5. Remove the following components:
  - a. Hard drive (see [Hard drive on page 45](#))
  - b. Optical drive (see [Optical drive on page 52](#))
  - c. Keyboard (see [Keyboard on page 54](#))
  - d. Hinge cover (see [Hinge cover on page 56](#))
  - e. Rear cover (see [Rear cover on page 57](#))
  - f. Top cover (see [Top cover on page 59](#))
  - g. Subwoofer (see [Subwoofer on page 72](#))

Remove the video connector board:

1. Disconnect the video connector board cable **(1)** from the system board.
2. Remove the Phillips PM2.5×4.0 screw **(2)** that secures the video connector board to the base enclosure.
3. Route the video connector board cable under the processor heat sink pipe **(3)**.
4. Remove the video connector board **(4)** from the base enclosure.

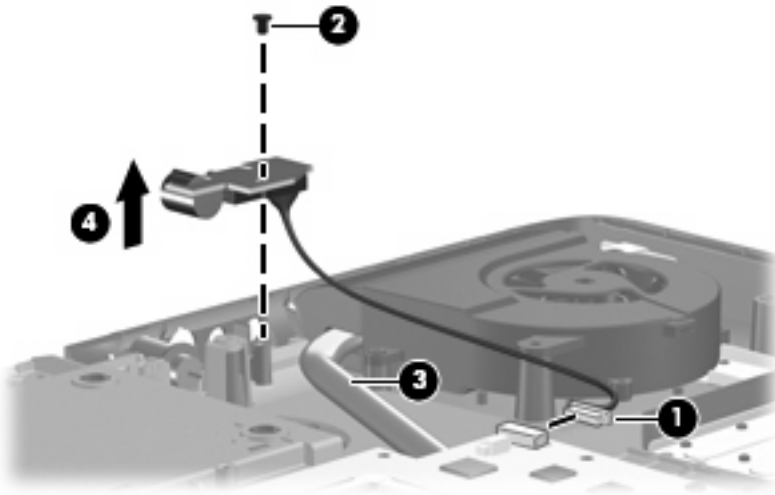

Reverse this procedure to install the video connector board.

## Processor fan

Description	Spare part number
Processor fan	448162-001

 **NOTE:** To properly ventilate the computer, allow at least a 7.6-cm (3-inch) clearance on the left and right sides and rear panel of the computer. The computer uses two electric fans for ventilation. The fans are controlled by a temperature sensor and are designed to turn on automatically when high temperature conditions exist. These conditions are affected by high external temperatures, system power consumption, power management/battery conservation configurations, battery fast charging, and software requirements. Exhaust air is displaced through the ventilation grills located on the computer rear panel.

Before removing the processor fan, follow these steps:

1. Shut down the computer. If you are unsure whether the computer is off or in Hibernation, turn the computer on, and then shut it down through the operating system.
2. Disconnect all external devices connected to the computer.
3. Disconnect the power from the computer by first unplugging the power cord from the AC outlet and then unplugging the AC adapter from the computer.
4. Remove the battery (see [Battery on page 38](#)).
5. Remove the following components:
  - a. Hard drive (see [Hard drive on page 45](#))
  - b. Optical drive (see [Optical drive on page 52](#))
  - c. Keyboard (see [Keyboard on page 54](#))
  - d. Hinge cover (see [Hinge cover on page 56](#))
  - e. Rear cover (see [Rear cover on page 57](#))
  - f. Top cover (see [Top cover on page 59](#))
  - g. Subwoofer (see [Subwoofer on page 72](#))

Remove the processor fan:

1. Disconnect the processor fan cable **(1)** from the system board.
2. Remove the two Phillips PM2.5×8.0 screws **(2)** that secure the processor fan to the base enclosure.

3. Remove the processor fan **(3)**.

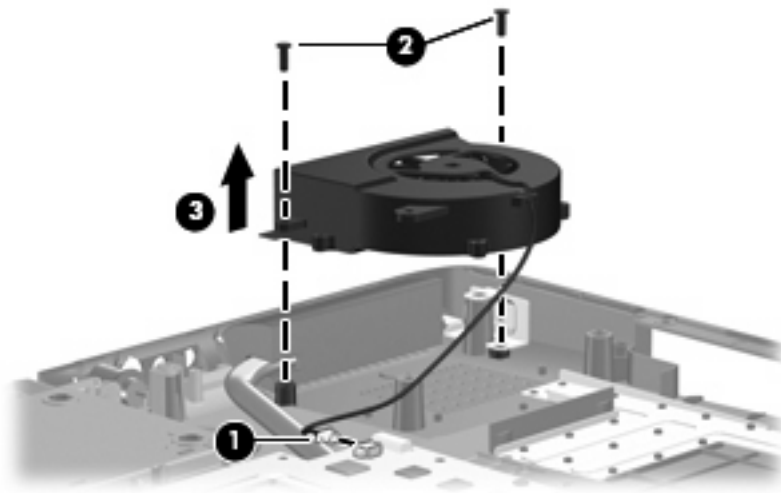

Reverse this procedure to install the processor fan.

## System board

Description	Spare part number
System board (includes power connector cable, ExpressCard assembly, and replacement thermal material)	448145-001

Before removing the system board, follow these steps:

1. Shut down the computer. If you are unsure whether the computer is off or in Hibernation, turn the computer on, and then shut it down through the operating system.
2. Disconnect all external devices connected to the computer.
3. Disconnect the power from the computer by first unplugging the power cord from the AC outlet and then unplugging the AC adapter from the computer.
4. Remove the battery (see [Battery on page 38](#)).
5. Remove the following components:
  - a. Hard drive (see [Hard drive on page 45](#))
  - b. Optical drive (see [Optical drive on page 52](#))
  - c. Keyboard (see [Keyboard on page 54](#))
  - d. Hinge cover (see [Hinge cover on page 56](#))
  - e. Rear cover (see [Rear cover on page 57](#))
  - f. Top cover (see [Top cover on page 59](#))
  - g. Subwoofer (see [Subwoofer on page 72](#))
  - h. Processor fan (see [Processor fan on page 75](#))

When replacing the system board, be sure that the following components are removed from the defective system board and installed on the replacement system board:

- Memory module (see [Memory module on page 50](#))
- RTC battery (see [RTC battery on page 81](#))
- WLAN module (see [WLAN module on page 47](#))

Remove the system board:

1. Remove the power connector **(1)** from the clip built into the base enclosure.
2. Disconnect the rear USB board cable **(2)** and the power connector LED board cable **(3)** from the system board.

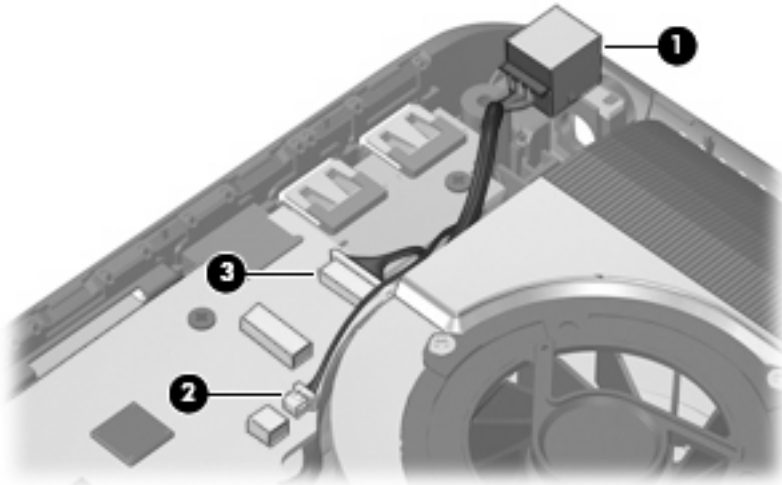

3. Disconnect the following cable connectors from the system board:

- (1) Speaker cable
- (2) Microphone cable
- (3) Audio/infrared board cable
- (4) Subwoofer cable
- (5) Audio connector board cable

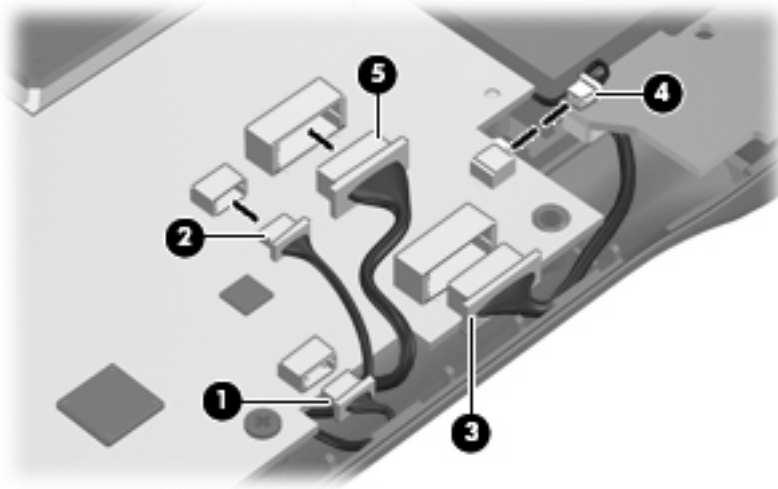

4. Disconnect the following cables from the system board:

- (1) Bluetooth module cable
- (2) Front USB board cable
- (3) Processor fan cable
- (4) Composite video connector board cable

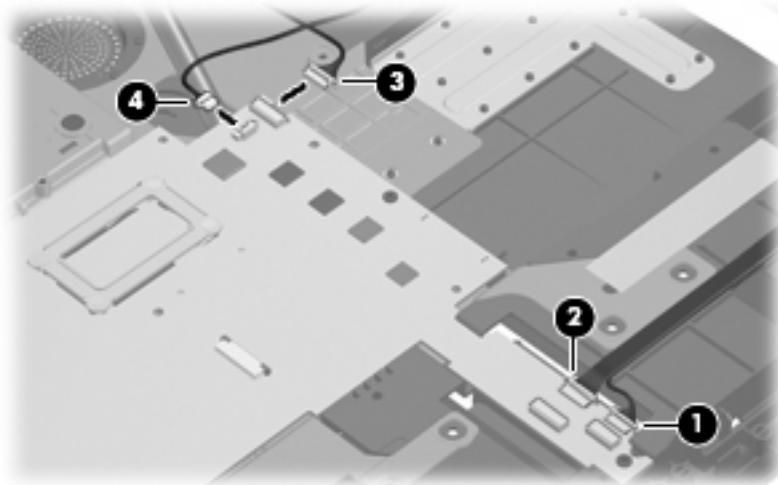

5. Remove the two SM1.5×9.0 screws **(1)** on each side of the expansion port 3 connector.

6. Remove the four Phillips PM2.5×4.0 screws **(2)** that secure the system board to the base enclosure.
7. Loosen the captive Phillips PM2.5×14.0 screw **(3)** that secures the video heat sink and system board to the base enclosure.

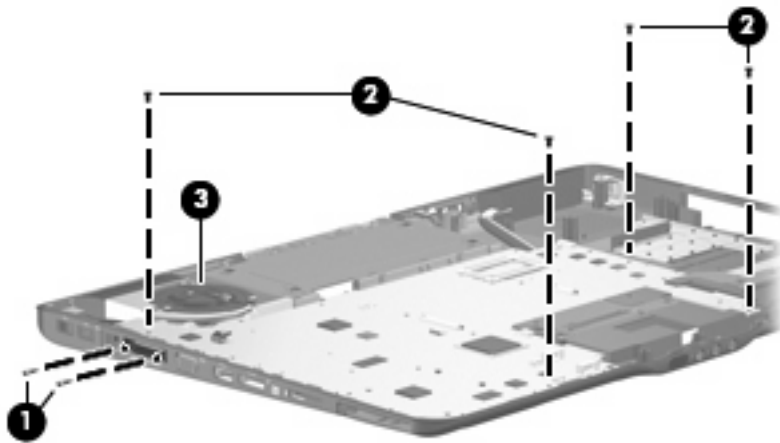

8. Use the optical drive connector **(1)** to lift the right side of the system board **(2)** until it rests at an angle.
9. Remove the system board **(3)** by pulling it away from the base enclosure at an angle.

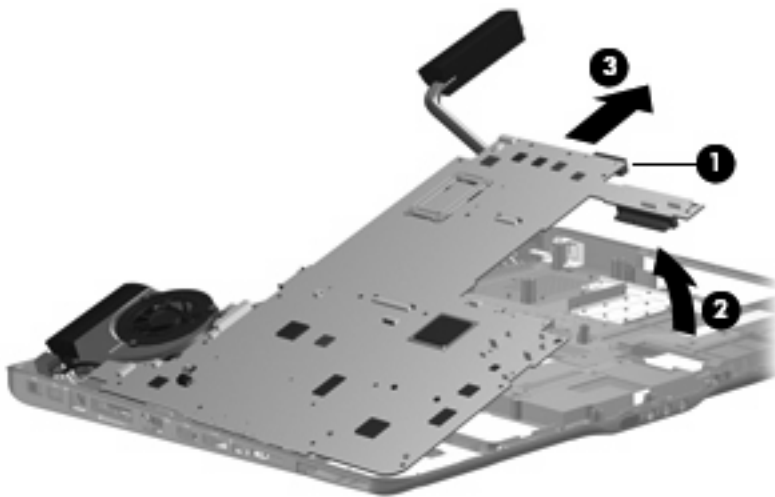

Reverse this procedure to install the system board.

## Audio connector board

Description	Spare part number
Audio connector board (includes cable)	452317-001

Before removing the audio connector board, follow these steps:

1. Shut down the computer. If you are unsure whether the computer is off or in Hibernation, turn the computer on, and then shut it down through the operating system.
2. Disconnect all external devices connected to the computer.
3. Disconnect the power from the computer by first unplugging the power cord from the AC outlet and then unplugging the AC adapter from the computer.
4. Remove the battery (see [Battery on page 38](#)).
5. Remove the following components:
  - a. Hard drive (see [Hard drive on page 45](#))
  - b. Optical drive (see [Optical drive on page 52](#))
  - c. Keyboard (see [Keyboard on page 54](#))
  - d. Hinge cover (see [Hinge cover on page 56](#))
  - e. Rear cover (see [Rear cover on page 57](#))
  - f. Top cover (see [Top cover on page 59](#))
  - g. Subwoofer (see [Subwoofer on page 72](#))
  - h. System board (see [System board on page 76](#))

Remove the audio connector board:

1. Remove the two Phillips PM2.5×5.0 screws **(1)** that secure the audio connector board to the base enclosure.
2. Remove the audio connector board cable **(2)** from the clips built into the base enclosure.



3. Remove the audio connector board **(3)** from the base enclosure.

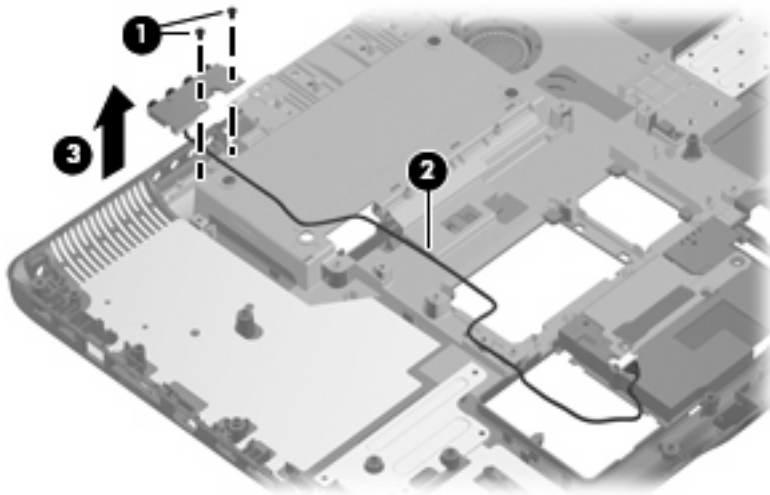

Reverse this procedure to install the audio connector board.

## RTC battery

 **NOTE:** Removing the RTC battery and leaving it uninstalled for 5 or more minutes causes all passwords and CMOS settings to be cleared.

Description	Spare part number
RTC battery	452319-001

Before removing the RTC battery, follow these steps:

1. Shut down the computer. If you are unsure whether the computer is off or in Hibernation, turn the computer on, and then shut it down through the operating system.
2. Disconnect all external devices connected to the computer.
3. Disconnect the power from the computer by first unplugging the power cord from the AC outlet and then unplugging the AC adapter from the computer.
4. Remove the battery (see [Battery on page 38](#)).
5. Remove the following components:
  - a. Hard drive (see [Hard drive on page 45](#))
  - b. Optical drive (see [Optical drive on page 52](#))
  - c. Keyboard (see [Keyboard on page 54](#))
  - d. Hinge cover (see [Hinge cover on page 56](#))
  - e. Rear cover (see [Rear cover on page 57](#))
  - f. Top cover (see [Top cover on page 59](#))

- g.** Subwoofer (see [Subwoofer on page 72](#))
- h.** System board (see [System board on page 76](#))

Remove the RTC battery:

- ▲ Remove the RTC battery from the socket on the system board.

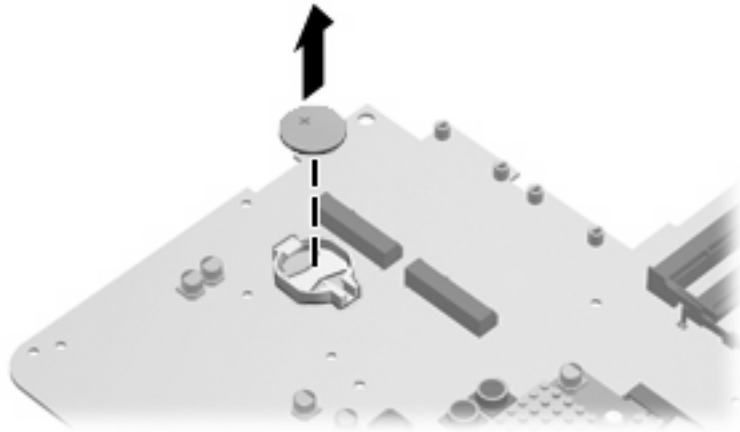

Reverse this procedure to install the RTC battery.

## Processor heat sink

Description	Spare part number
Processor heat sink (includes replacement thermal material)	448175-001

Before removing the processor heat sink, follow these steps:

1. Shut down the computer. If you are unsure whether the computer is off or in Hibernation, turn the computer on, and then shut it down through the operating system.
2. Disconnect all external devices connected to the computer.
3. Disconnect the power from the computer by first unplugging the power cord from the AC outlet and then unplugging the AC adapter from the computer.
4. Remove the battery (see [Battery on page 38](#)).
5. Remove the following components:
  - a. Hard drive (see [Hard drive on page 45](#))
  - b. Optical drive (see [Optical drive on page 52](#))
  - c. Keyboard (see [Keyboard on page 54](#))
  - d. Hinge cover (see [Hinge cover on page 56](#))
  - e. Rear cover (see [Rear cover on page 57](#))
  - f. Top cover (see [Top cover on page 59](#))
  - g. Subwoofer (see [Subwoofer on page 72](#))
  - h. System board (see [System board on page 76](#))

Remove the processor heat sink:

1. Turn the system board upside down, with the front toward you.
2. Loosen the three silver Phillips PM2.0×5.0 captive screws **(1)** that secure the processor heat sink to the system board.
3. Remove the processor heat sink clip **(2)** by sliding it to the right.

4. Remove the processor heat sink **(3)**.

 **NOTE:** Due to the adhesive quality of the thermal material located between the processor heat sink and system board components, it may be necessary to move the processor heat sink from side to side to detach it.

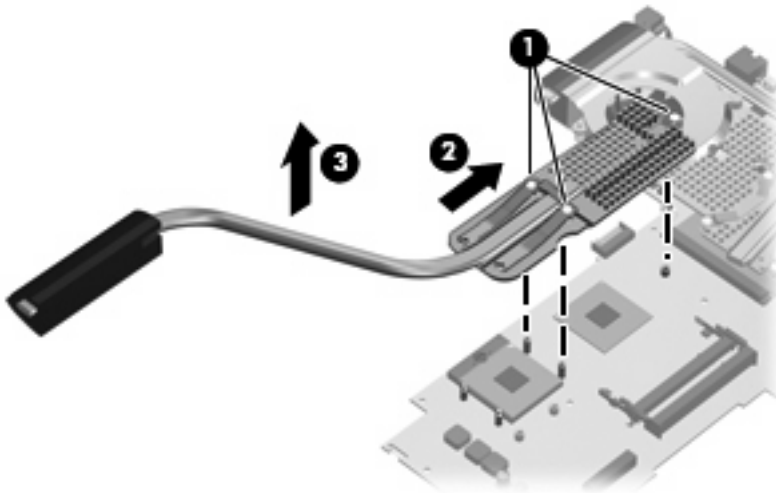

 **NOTE:** The thermal material must be thoroughly cleaned from the surfaces of the processor heat sink **(1)** and the system board **(2)** each time the processor heat sink is removed. Thermal material must be installed on all surfaces before the processor heat sink is reinstalled. Replacement thermal material is included with all processor heat sink, system board, and processor spare part kits, and is also available using spare part number 413706-001.

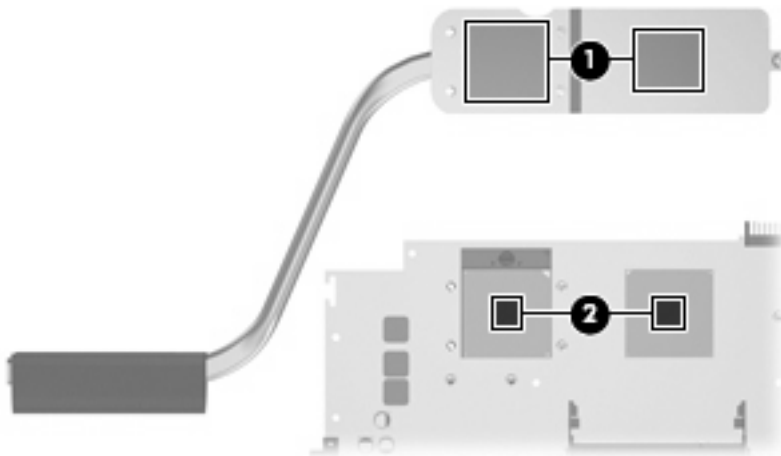

Reverse this procedure to install the processor heat sink.

## Processor

 **NOTE:** All processor spare part kits include replacement thermal material.

Description	Spare part number
<b>Intel Core 2 Extreme processors (4-MB L2 cache, 800-MHz FSB, 44-W):</b>	
X7900 2.8-GHz processor	453908-001
X7800 2.6-GHz processor	455738-001 and 452327-001
<b>Intel Core 2 Duo processors (4-MB L2 cache, 800-MHz FSB, 35-W):</b>	
T7700 2.4-GHz processor	448148-001
T7500 2.2-GHz processor	448147-001
T7300 2.0-GHz processor	448146-001
T7100 1.8-GHz processor	448149-001

Before removing the processor, follow these steps:

1. Shut down the computer. If you are unsure whether the computer is off or in Hibernation, turn the computer on, and then shut it down through the operating system.
2. Disconnect all external devices connected to the computer.
3. Disconnect the power from the computer by first unplugging the power cord from the AC outlet and then unplugging the AC adapter from the computer.
4. Remove the battery (see [Battery on page 38](#)).
5. Remove the following components:
  - a. Hard drive (see [Hard drive on page 45](#))
  - b. Optical drive (see [Optical drive on page 52](#))
  - c. Keyboard (see [Keyboard on page 54](#))
  - d. Hinge cover (see [Hinge cover on page 56](#))
  - e. Rear cover (see [Rear cover on page 57](#))
  - f. Top cover (see [Top cover on page 59](#))
  - g. Subwoofer (see [Subwoofer on page 72](#))
  - h. System board (see [System board on page 76](#))
  - i. Processor heat sink (see [Processor heat sink on page 83](#))

Remove the processor:

1. Turn the processor locking screw **(1)** one-half turn counterclockwise until you hear a click.

2. Lift the processor **(2)** straight up and remove it.

 **NOTE:** The gold triangle **(3)** on the processor must be aligned with the triangle icon **(4)** embossed on the processor slot when you install the processor.

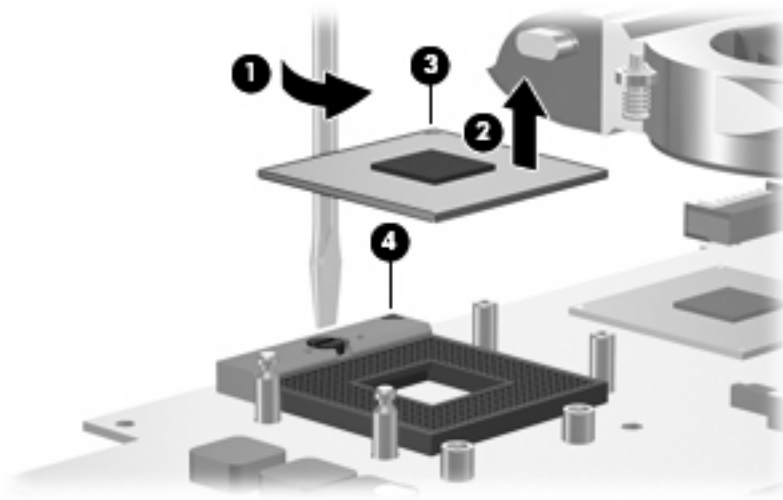

Reverse this procedure to install the processor.

## Video board heat sink

Description	Spare part number
Video board heat sink (includes replacement thermal material)	448176-001

Before removing the video board heat sink, follow these steps:

1. Shut down the computer. If you are unsure whether the computer is off or in Hibernation, turn the computer on, and then shut it down through the operating system.
2. Disconnect all external devices connected to the computer.
3. Disconnect the power from the computer by first unplugging the power cord from the AC outlet and then unplugging the AC adapter from the computer.
4. Remove the battery (see [Battery on page 38](#)).
5. Remove the following components:
  - a. Hard drive (see [Hard drive on page 45](#))
  - b. Optical drive (see [Optical drive on page 52](#))
  - c. Keyboard (see [Keyboard on page 54](#))
  - d. Hinge cover (see [Hinge cover on page 56](#))
  - e. Rear cover (see [Rear cover on page 57](#))
  - f. Top cover (see [Top cover on page 59](#))
  - g. Subwoofer (see [Subwoofer on page 72](#))
  - h. System board (see [System board on page 76](#))

Remove the video board heat sink:

1. Turn the system board upside down, with the front toward you.
2. Disconnect the video board fan cable **(1)** from the system board.
3. Loosen the two Phillips PM2.5×9.0 captive screws **(2)** and the four silver Phillips PM2.0×5.0 captive screws **(3)** that secure the video board heat sink to the system board.

4. Remove the video board heat sink (4).

 **NOTE:** Due to the adhesive quality of the thermal material located between the video board heat sink and system board components, it may be necessary to move the video board heat sink from side to side to detach it.

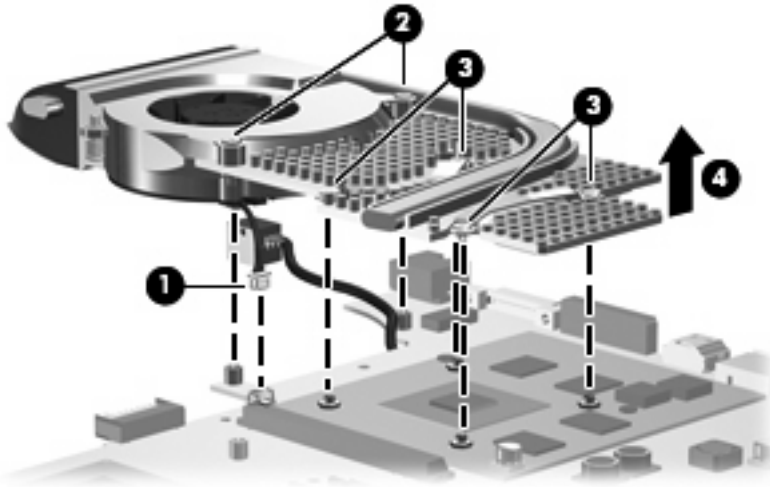

 **NOTE:** The thermal material must be thoroughly cleaned from the surfaces of the video board components (1) and the video board heat sink (2) each time the video board heat sink is removed. Thermal material must be installed on all surfaces before the video board heat sink is reinstalled. Replacement thermal material is included with all video board heat sink and video board spare part kits, and is also available using spare part number 413706-001.

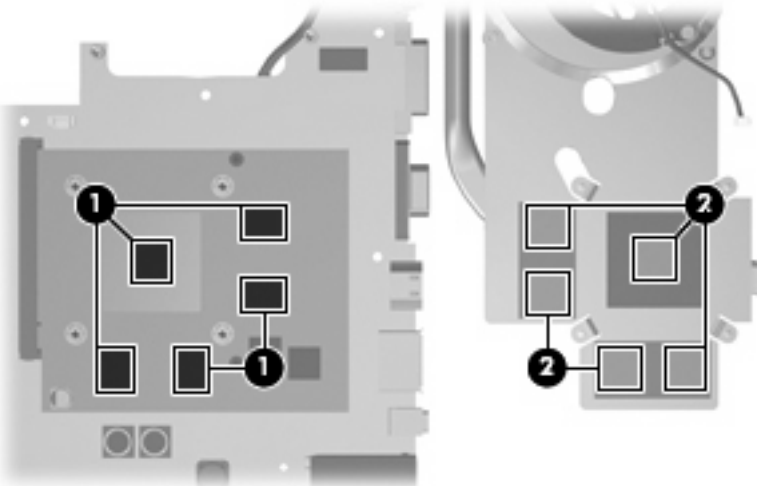

Reverse this procedure to install the video board heat sink.



## Video board fan

Description	Spare part number
Video board fan	448163-001

 **NOTE:** To properly ventilate the computer, allow at least a 7.6-cm (3-inch) clearance on the left and right sides and rear panel of the computer. The computer uses two electric fans for ventilation. The fans are controlled by a temperature sensor and are designed to turn on automatically when high temperature conditions exist. These conditions are affected by high external temperatures, system power consumption, power management/battery conservation configurations, battery fast charging, and software requirements. Exhaust air is displaced through the ventilation grills located on the computer rear panel.

Before removing the video board fan, follow these steps:

1. Shut down the computer. If you are unsure whether the computer is off or in Hibernation, turn the computer on, and then shut it down through the operating system.
2. Disconnect all external devices connected to the computer.
3. Disconnect the power from the computer by first unplugging the power cord from the AC outlet and then unplugging the AC adapter from the computer.
4. Remove the battery (see [Battery on page 38](#)).
5. Remove the following components:
  - a. Hard drive (see [Hard drive on page 45](#))
  - b. Optical drive (see [Optical drive on page 52](#))
  - c. Keyboard (see [Keyboard on page 54](#))
  - d. Hinge cover (see [Hinge cover on page 56](#))
  - e. Rear cover (see [Rear cover on page 57](#))
  - f. Top cover (see [Top cover on page 59](#))
  - g. Subwoofer (see [Subwoofer on page 72](#))
  - h. System board (see [System board on page 76](#))
  - i. Video board heat sink (see [Video board heat sink on page 87](#))

Remove the video board fan:

1. Turn the video heat sink upside down.
2. Remove the three black Phillips PM2.0×4.0 screws **(1)** that secure the video board fan to the video board heat sink.

3. Remove the video board fan **(2)**.

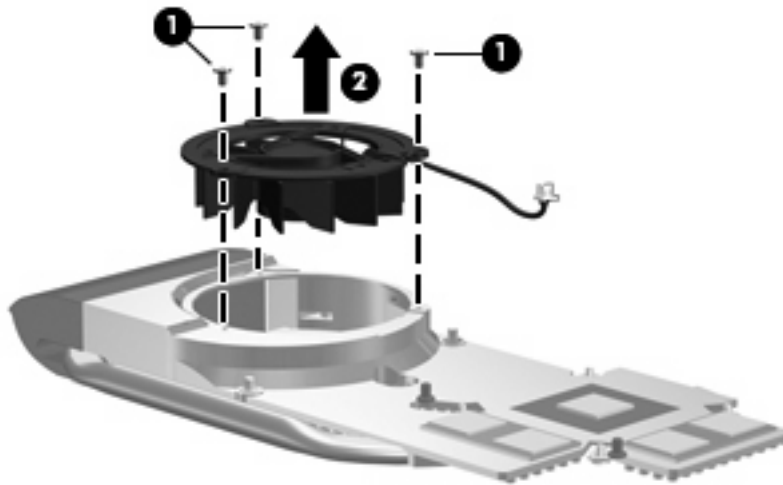

Reverse this procedure to install the video board fan.

## Video board

Description	Spare part number
nVidia video board (includes replacement thermal material)	454311-001

Before removing the video board fan, follow these steps:

1. Shut down the computer. If you are unsure whether the computer is off or in Hibernation, turn the computer on, and then shut it down through the operating system.
2. Disconnect all external devices connected to the computer.
3. Disconnect the power from the computer by first unplugging the power cord from the AC outlet and then unplugging the AC adapter from the computer.
4. Remove the battery (see [Battery on page 38](#)).
5. Remove the following components:
  - a. Hard drive (see [Hard drive on page 45](#))
  - b. Optical drive (see [Optical drive on page 52](#))
  - c. Keyboard (see [Keyboard on page 54](#))
  - d. Hinge cover (see [Hinge cover on page 56](#))
  - e. Rear cover (see [Rear cover on page 57](#))
  - f. Top cover (see [Top cover on page 59](#))
  - g. Subwoofer (see [Subwoofer on page 72](#))

- h. System board (see [System board on page 76](#))
- i. Video board heat sink (see [Video board heat sink on page 87](#))

Remove the video board:

1. Remove the two Phillips PM2.5×4.0 screws **(1)** that secure the video board to the system board.
2. Lift the right side of the video board **(2)** until it rests at an angle.
3. Remove the video board **(3)** by pulling it away from the video board slot at an angle.

---

 **NOTE:** Video boards are designed with a notch **(4)** to prevent incorrect installation into the video board slot.

---

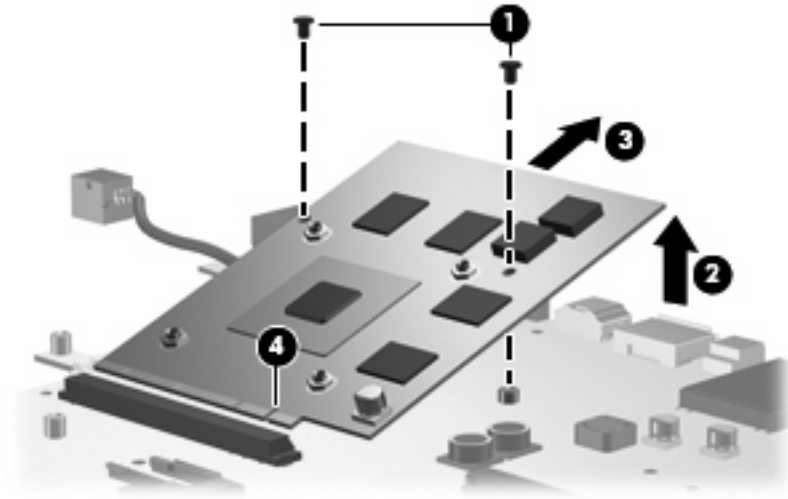

Reverse this procedure to install the video board.

---

# 5 Computer Setup

## Starting Computer Setup

Computer Setup is a ROM-based information and customization utility that can be used even when the Windows operating system is not working or will not load.

---

 **NOTE:** The fingerprint reader does not work when accessing Computer Setup.

---

The utility reports information about the computer and provides settings for startup, security, and other preferences.

To start Computer Setup:

1. Turn on or restart the computer.
2. Before Windows opens and while "F10 = ROM Based Setup" is displayed in the lower-left corner of the screen, press [f10](#).

# Using Computer Setup

## Changing the language of Computer Setup

The following procedure explains how to change the language of Computer Setup. If Computer Setup is not already running, begin at step 1.

1. To start Computer Setup, turn on or restart the computer, and then press **f10** while “F10 = ROM Based Setup” is displayed in the lower-left corner of the screen.
2. Use the arrow keys to select **System Configuration > Language**, and then press **enter**.
3. Use the arrow keys to select a language, and then press **f10**.
4. When the confirmation prompt is displayed, press **f10** to save your preference.
5. To set your preferences and exit Computer Setup, select **File > Save Changes And Exit**, and then follow the instructions on the screen.

Your preferences go into effect when the computer restarts in Windows.

## Navigating and selecting in Computer Setup

Because Computer Setup is not Windows-based, it does not support the TouchPad. Navigation and selection are by keystroke.

- To choose a menu or a menu item, use the arrow keys.
- To select an item, press **f10**.
- To close a text box or return to the menu display, press **esc**.
- To display additional navigation and selection information while Computer Setup is open,, press **f1**.

## Displaying system information

The following procedure explains how to display system information in Computer Setup. If Computer Setup is not open, begin at step 1. If Computer Setup is open, begin at step 2.

1. To start Computer Setup, turn on or restart the computer, and then press **f10** while “F10 = ROM Based Setup” is displayed in the lower-left corner of the screen.
2. Access the system information by using the **File** menu.
3. To exit Computer Setup without changing any settings, use the arrow keys to select **File > Ignore Changes And Exit**, and then follow the instructions on the screen.

## Restoring default settings in Computer Setup

The following procedure explains how to restore Computer Setup default settings. If Computer Setup is not already running, begin at step 1. If Computer Setup is already running, begin at step 2.

1. To start Computer Setup, turn on or restart the computer, and then press **f10** while “F10 = ROM Based Setup” is displayed in the lower-left corner of the screen.
2. Select **File > Restore Defaults**, and then press **enter**.
3. Follow the instructions on the screen.

Computer Setup default settings are set when you exit Computer Setup and go into effect when the computer restarts.

---

 **NOTE:** Your password, security, and language settings are not changed when you restore the factory default settings.

---

## Closing Computer Setup

You can close Computer Setup with or without saving changes.

- To close Computer Setup and save your changes from the current session, use either of the following procedures:

- Press **f10**, and then follow the instructions on the screen.

– or –

- If the Computer Setup menus are not visible, press **esc** to return to the menu display. Then use the arrow keys to select **File > Save Changes And Exit**, and then press **enter**.

When you use the **f10** procedure, you are offered an option to return to Computer Setup. When you use the Save Changes And Exit procedure, Computer Setup closes when you press **enter**.

- To close Computer Setup without saving your changes from the current session:

If the Computer Setup menus are not visible, press **esc** to return to the menu display. Then use the arrow keys to select **File > Ignore Changes And Exit**, and then press **enter**.

After Computer Setup closes, the computer restarts in Windows.

# Computer Setup menus

The menu tables in this section provide an overview of Computer Setup options.

 **NOTE:** Some of the Computer Setup menu items listed in this chapter may not be supported by your computer.

## File menu

Select	To do this
System information	<ul style="list-style-type: none"><li>• View identification information about the computer.</li><li>• View specification information for the processor, memory, and system ROM.</li></ul>
Restore defaults	Replace the configuration settings in Computer Setup with factory settings. (Password and security settings are not changed when you restore the factory settings.)
Ignore changes and exit	Cancel any changes entered during the current session. Then exit and restart the computer.
Save changes and exit	Save changes entered during the current session. Then exit and restart the computer. Your changes go into effect when the computer restarts.

## Security menu

Select	To do this
Setup password	Enter, change, or delete a setup password.
Power-On password	Enter, change, or delete a power-on password.

## Diagnostics menu

Select	To do this
Hard Drive Self-Test options	Run a comprehensive self-test on any hard drive in the system.
Memory Check	Run a comprehensive check on system memory.



## System Configuration menu

 **NOTE:** Some of the listed System Configuration options may not be supported by your computer.

Select	To do this
Language (or press <a href="#">f2</a> )	Change the Computer Setup language.
Boot options	<ul style="list-style-type: none"><li>• Set <a href="#">f9</a>, <a href="#">f10</a>, and <a href="#">f12</a> delay when starting up.</li><li>• Enable/disable CD-ROM boot.</li><li>• Enable/disable floppy boot.</li><li>• Enable/disable internal network adapter boot.</li><li>• Set the Express Boot Popup delay in seconds.</li><li>• Set the boot order.</li></ul>
Device configurations	<ul style="list-style-type: none"><li>• Enable/disable Virtualization Technology.</li><li>• Enable/disable button sound.</li></ul>

# 6 Specifications

## Computer specifications

	Metric	U.S.
<b>Dimensions</b>		
Width	47.5 cm	18.70 in
Depth	33.9 cm	13.35 in
Height	5.9 cm	2.32 in
<b>Weight</b> (with optical drive, hard drive, and battery)	7.00 kg	15.44 lbs
Second hard drive adds:	0.13 kg	0.28 lbs
Camera adds:	0.009 kg	0.02 lbs
<b>Input power</b>		
Operating voltage	18.5 V dc @ 3.5 A - 180 W	
Operating current	3.5 A or 4.74 A	
<b>Temperature</b>		
Operating (not writing to optical disc)	0°C to 35°C	32°F to 95°F
Operating (writing to optical disc)	5°C to 35°C	41°F to 95°F
Nonoperating	-20°C to 60°C	-4°F to 140°F
<b>Relative humidity</b>		
Operating	10% to 90%	
Nonoperating	5% to 95%	
<b>Maximum altitude</b> (unpressurized)		
Operating (14.7 to 10.1 psia)	-15 m to 3,048 m	-50 ft to 10,000 ft
Nonoperating (14.7 to 4.4 psia)	-15 m to 12,192 m	-50 ft to 40,000 ft
<b>Shock</b>		
Operating	125 g, 2 ms, half-sine	
Nonoperating	200 g, 2 ms, half-sine	
<b>Random vibration</b>		

	Metric	U.S.
Operating	0.75 g zero-to-peak, 10 Hz to 500 Hz, 0.25 oct/min sweep rate	
Nonoperating	1.50 g zero-to-peak, 10 Hz to 500 Hz, 0.5 oct/min sweep rate	

**NOTE:** Applicable product safety standards specify thermal limits for plastic surfaces. The computer operates well within this range of temperatures.

## 20.1-inch, WUXGA display specifications

	Metric	U.S.
<b>Dimensions</b>		
Height	27.40 cm	10.79 in
Width	43.55 cm	17.15 in
Diagonal	51.10 cm	20.11 in
<b>Number of colors</b>	Up to 16.8 million	
<b>Contrast ratio</b>	200:1 (typical)	
<b>Brightness</b>	180 nits (typical)	
<b>Pixel resolution</b>		
Pitch	0.172 × 0.172 mm	
Format	1920 × 1200	
Configuration	RGB vertical stripe	
<b>Backlight</b>	CCFT	
<b>Character display</b>	80 × 25	
<b>Total power consumption</b>	6.0 W	
<b>Viewing angle</b>	+/-65° horizontal, +/-50° vertical (typical)	

## 20.1-inch WSXGA+ display specifications

	Metric	U.S.
<b>Dimensions</b>		
Height	27.40 cm	10.79 in
Width	43.55 cm	17.15 in
Diagonal	51.10 cm	20.11 in
<b>Number of colors</b>	Up to 16.8 million	
<b>Contrast ratio</b>	200:1	
<b>Brightness</b>	180 nits typical	
<b>Pitch resolution</b>		
Pitch	0.172 × 0.172 mm	
Format	1680 × 1050	
Configuration	RGB vertical stripe	
<b>Backlight</b>	CCFT	
<b>Character display</b>	80 × 25	
<b>Total power consumption</b>	7.0 W	
<b>Viewing angle</b>	+/-60° horizontal, +40/-50° vertical typical	

# Hard drive specifications

	250-GB*	200-GB*	160-GB*	120-GB*	100-GB*
<b>Dimensions</b>					
Height	9.5 mm	9.5 mm	9.5 mm	9.5 mm	9.5 mm
Width	70 mm	70 mm	70 mm	70 mm	70 mm
Weight	101 g	101 g	101 g	101 g	101 g
<b>Interface type</b>					
	ATA-7	ATA-7	ATA-7	ATA-7	ATA-7
<b>Transfer rate</b>					
Synchronous (maximum)	100 MB/sec	100 MB/sec	100 MB/sec	100 MB/sec	100 MB/sec
Security	ATA security	ATA security	ATA security	ATA security	ATA security
<b>Seek times</b> (typical read, including setting)					
Single track	3 ms	3 ms	3 ms	3 ms	3 ms
Average	13 ms	13 ms	13 ms	13 ms	13 ms
Maximum	24 ms	24 ms	24 ms	24 ms	24 ms
<b>Logical blocks</b>					
	495,665,155	396,532,124	317,249,699	237,937,274	198,281,062
<b>Disc rotational speed</b>					
	5400-rpm	4200-rpm	5400-rpm	7200- and 5400-rpm	5400-rpm
<b>Operating temperature</b>					
	5°C to 55°C (41°F to 131°F)				
*1 GB = 1 billion bytes when referring to hard drive storage capacity. Actual accessible capacity is less.					
<b>NOTE:</b> Certain restrictions and exclusions apply. Contact technical support for details.					

# DVD±RW and CD-RW Super Multi Double-Layer Combo Drive specifications

<b>Applicable disc</b>	<b>Read:</b>	<b>Write:</b>
	CD-DA, CD+(E)G, CD-MIDI, CD-TEXT, CD-ROM, CD-ROM XA, MIXED MODE CD, CD-I, CD-I Bridge (Photo-CD, Video CD), Multisession CD (Photo-CD, CD-EXTRA, Portfolio, CD-R, CD-RW), CD-R, CD-RW, DVD-ROM (DVD-5, DVD-9, DVD-10, DVD-18), DVD-R, DVD-RW, DVD+R, DVD+RW, DVD-RAM	CD-R and CD-RW DVD+R, DVD+RW, DVD-R, DVD-RW, DVD-RAM
<b>Center hole diameter</b>	1.5 cm (0.59 in)	
<b>Disc diameter</b>		
Standard disc	12 cm (4.72 in)	
Mini disc	8 cm (3.15 in)	
<b>Disc thickness</b>	1.2 mm (0.047 in)	
<b>Track pitch</b>	0.74 μm	
<b>Access time</b>	<b>CD</b>	<b>DVD</b>
Random	< 175 ms	< 230 ms
Full stroke	< 285 ms	< 335 ms
<b>Audio output level</b>	Audio-out, 0.7 Vrms	
<b>Cache buffer</b>	2 MB	
<b>Data transfer rate</b>		
24X CD-ROM	3,600 KB/sec	
8X DVD	10,800 KB/sec	
24X CD-R	3,600 KB/sec	
16X CD-RW	2,400 KB/sec	
8X DVD+R	10,800 KB/sec	
4X DVD+RW	5,400 KB/sec	
8X DVD-R	10,800 KB/sec	
4X DVD-RW	5,400 KB/sec	
2.4X DVD+R(9)	2,700 KB/sec	
5X DVD-RAM	6,750 KB/sec	
<b>Transfer mode</b>	Multiword DMA Mode	
<b>Startup time</b>	< 15 seconds	
<b>Stop time</b>	< 6 seconds	

# System DMA specifications

Hardware DMA	System function
DMA0	Not applicable
DMA1*	Not applicable
DMA2*	Not applicable
DMA3	Not applicable
DMA4	Direct memory access controller
DMA5*	Available for PC Card
DMA6	Not assigned
DMA7	Not assigned

\*PC Card controller can use DMA 1, 2, or 5.

# System interrupt specifications

Hardware IRQ	System function
IRQ0	System timer
IRQ1	Standard 101-/102-Key or Microsoft® Natural Keyboard
IRQ2	Cascaded
IRQ3	Intel 82801DB/DBM USB2 Enhanced Host Controller—24CD
IRQ4	COM1
IRQ5*	Conexant AC—Link Audio Intel 82801DB/DBM SMBus Controller—24C3 Data Fax Modem with SmartCP
IRQ6	Diskette drive
IRQ7*	Parallel port
IRQ8	System CMOS/real-time clock
IRQ9*	Microsoft ACPI-compliant system
IRQ10*	Intel USB UHCI controller—24C2 Intel 82852/82855 GM/GME Graphic Controller Realtek RTL8139 Family PCI Fast Ethernet Controller
IRQ11	Intel USB EHCI controller—24CD Intel USB UHCI controller—24C4 Intel USB UHCI controller—24C7 Intel Pro/Wireless 2200BG TI OHCI 1394 host controller TI PCI1410 CardBus controller
IRQ12	Synaptics PS/2 TouchPad
IRQ13	Numeric data processor
IRQ14	Primary IDE channel
IRQ15	Secondary IDE channel

\*Default configuration; audio possible configurations are IRQ5, IRQ7, IRQ9, IRQ10, or none.

**NOTE:** PC Cards may assert IRQ3, IRQ4, IRQ5, IRQ7, IRQ9, IRQ10, IRQ11, or IRQ15. Either the infrared or the serial port may assert IRQ3 or IRQ4.



# System I/O address specifications

I/O address (hex)	System function (shipping configuration)
000 - 00F	DMA controller no. 1
010 - 01F	Unused
020 - 021	Interrupt controller no. 1
022 - 024	Opti chipset configuration registers
025 - 03F	Unused
02E - 02F	87334 "Super I/O" configuration for CPU
040 - 05F	Counter/timer registers
044 - 05F	Unused
060	Keyboard controller
061	Port B
062 - 063	Unused
064	Keyboard controller
065 - 06F	Unused
070 - 071	NMI enable/RTC
072 - 07F	Unused
080 - 08F	DMA page registers
090 - 091	Unused
092	Port A
093 - 09F	Unused
0A0 - 0A1	Interrupt controller no. 2
I/O Address (hex)	System function (shipping configuration)
0A2 - 0BF	Unused
0C0 - 0DF	DMA controller no. 2
0E0 - 0EF	Unused
0F0 - 0F1	Coprocessor busy clear/reset
0F2 - 0FF	Unused
100 - 16F	Unused
170 - 177	Secondary fixed disk controller
178 - 1EF	Unused
1F0 - 1F7	Primary fixed disk controller
1F8 - 200	Unused
201	JoyStick (decoded in ESS1688)
202 - 21F	Unused

<b>I/O address (hex)</b>	<b>System function (shipping configuration)</b>
220 - 22F	Entertainment audio
230 - 26D	Unused
26E - 26	Unused
278 - 27F	Unused
280 - 2AB	Unused
2A0 - 2A7	Unused
2A8 - 2E7	Unused
2E8 - 2EF	Reserved serial port
2F0 - 2F7	Unused
2F8 - 2FF	Infrared port
300 - 31F	Unused
320 - 36F	Unused
370 - 377	Secondary diskette drive controller
378 - 37F	Parallel port (LPT1/default)
380 - 387	Unused
388 - 38B	FM synthesizer—OPL3
38C - 3AF	Unused
3B0 - 3BB	VGA
3BC - 3BF	Reserved (parallel port/no EPP support)
3C0 - 3DF	VGA
3E0 - 3E1	PC Card controller in CPU
3E2 - 3E3	Unused
3E8 - 3EF	Internal modem
3F0 - 3F7	"A" diskette controller
3F8 - 3FF	Serial port (COM1/default)
CF8 - CFB	PCI configuration index register (PCIDIVO-1)
CFC - CFF	PCI configuration data register (PCIDIVO-1)

# System memory map specifications

Size	Memory address	System function
640 KB	00000000-0009FFFF	Base memory
128 KB	000A0000-000BFFFF	Video memory
48 KB	000C0000-000CBFFF	Video BIOS
160 KB	000C8000-000E7FFF	Unused
64 KB	000E8000-000FFFFF	System BIOS
15 MB	00100000-00FFFFFF	Extended memory
58 MB	04800000-07FFFFFF	Super extended memory
58 MB	04800000-07FFFFFF	Unused
2 MB	08000000-080FFFFF	Video memory (direct access)
4 GB	08200000-FFFFFF	Unused
64 KB	FFFF0000-FFFFFFFF	System BIOS

## 7 Screw listing

This section provides specification and reference information for the screws and screw locks used in the computer. All screws and screw locks listed in this section are available in the Screw Kit, spare part number 448172-001, and the Display Screw Kit, spare part number 452309-001.

### Phillips PM2.5×5.0 screw

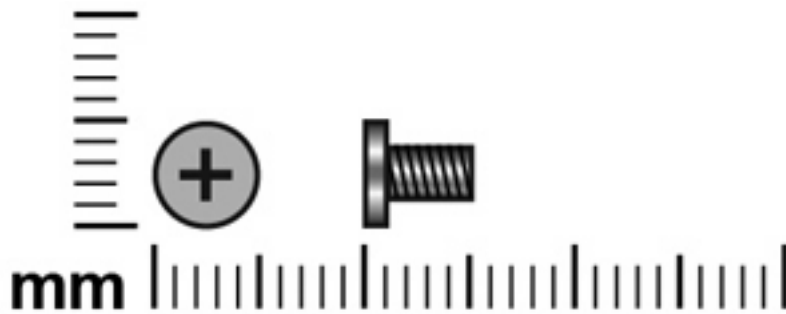

Color	Quantity	Length	Thread	Head diameter
Black	49	5.0 mm	2.5 mm	5.0 mm

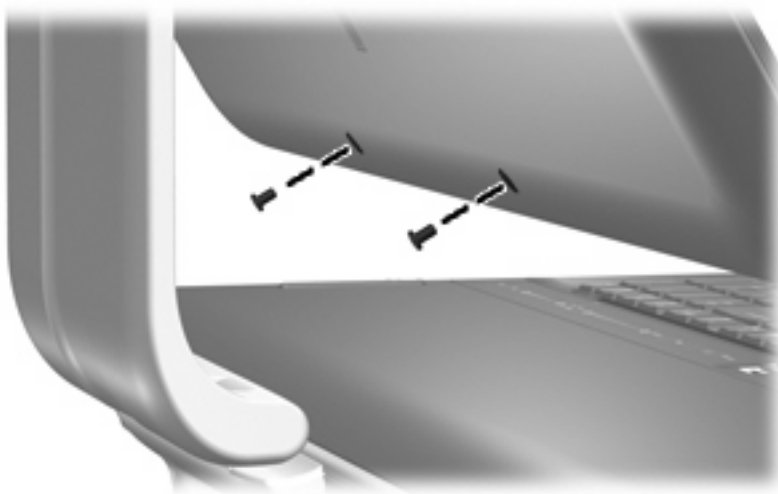

**Where used:** 2 screws that secure the display bezel to the display assembly

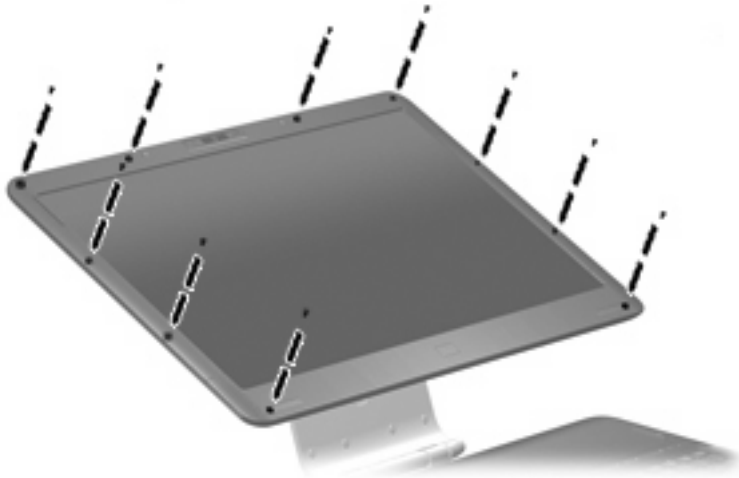

**Where used:** 10 screws that secure the display bezel to the display assembly

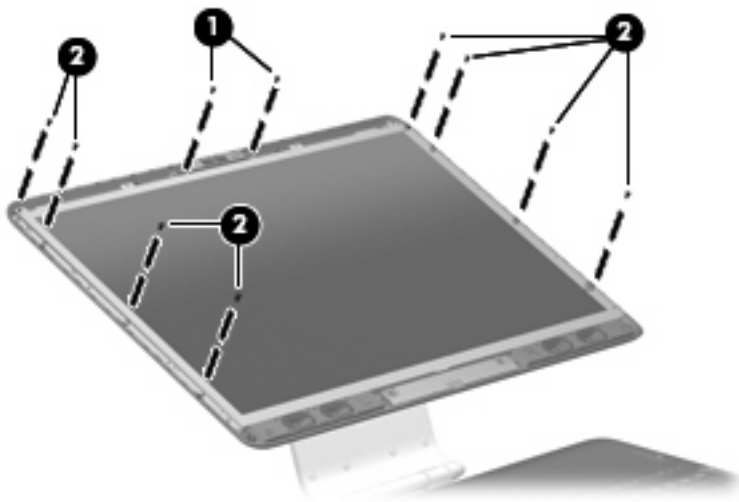

**Where used:**

**(1)** Two screws that secure the camera module to the display enclosure

**(2)** Eight screws that secure the display panel to the display enclosure

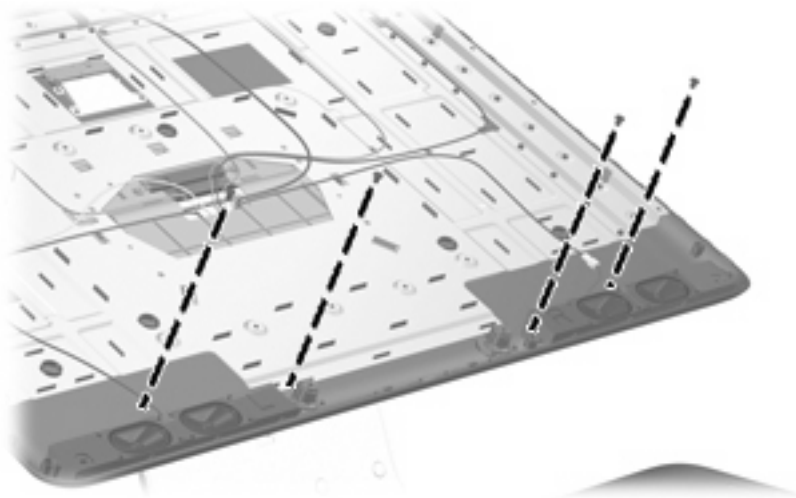

**Where used:** 4 screws that secure the speakers to the display enclosure

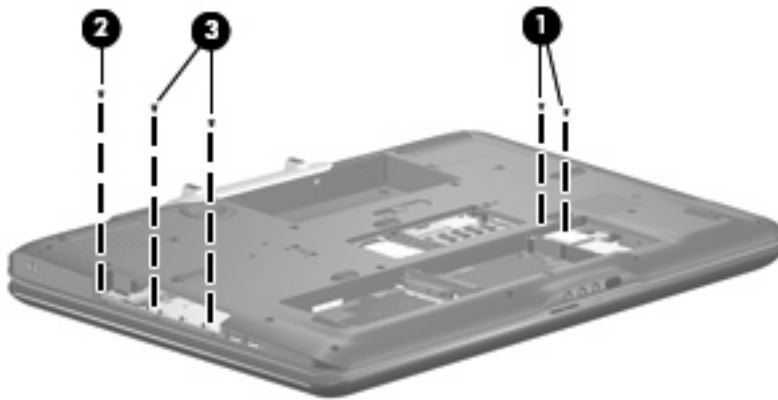

**Where used:**

- (1) Two screws that secure the WLAN module to the system board
- (2) One screw that secures the rear cover to the computer
- (3) Two screws that secure the top cover to the computer

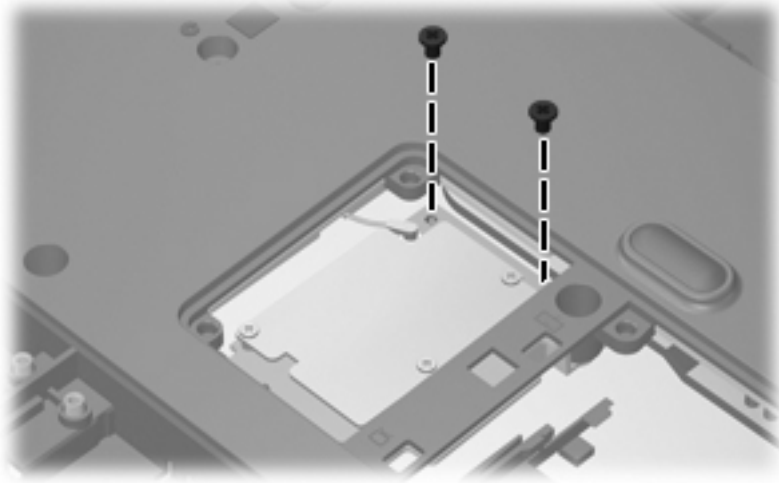

**Where used:** 2 screws that secure the TV tuner module to the system board

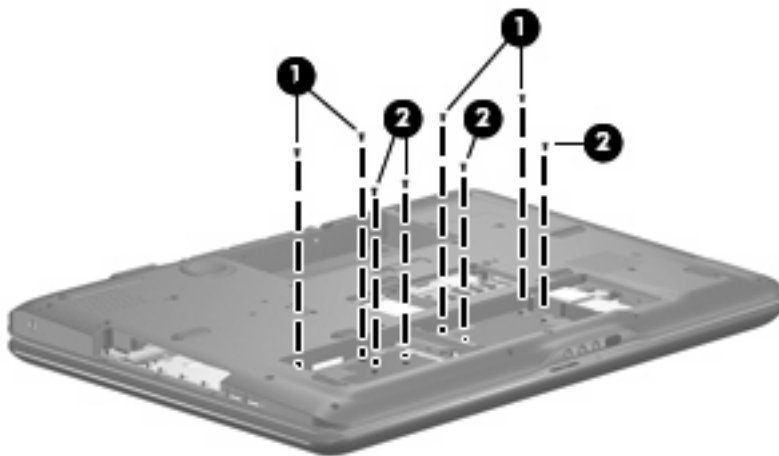

**Where used:**

**(1)** Four screws that secure the keyboard to the computer

**(2)** Four screws that secure the top cover to the computer

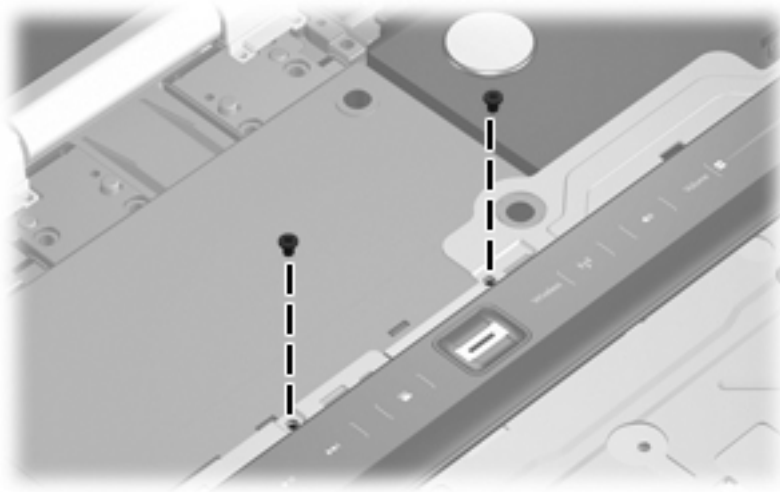

**Where used:** 2 screws that secure the top cover to the computer

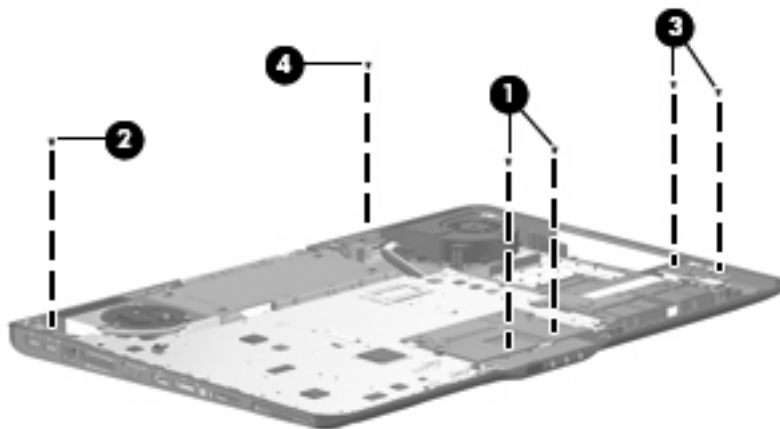

**Where used:**

- (1) Two screws that secure the audio/infrared board to the base enclosure
- (2) One screw that secures the rear USB board to the base enclosure
- (3) Two screws that secure the front USB board to the base enclosure
- (4) One screw that secures the video connector board to the base enclosure



## Black Phillips PM2.0×5.0 captive screw

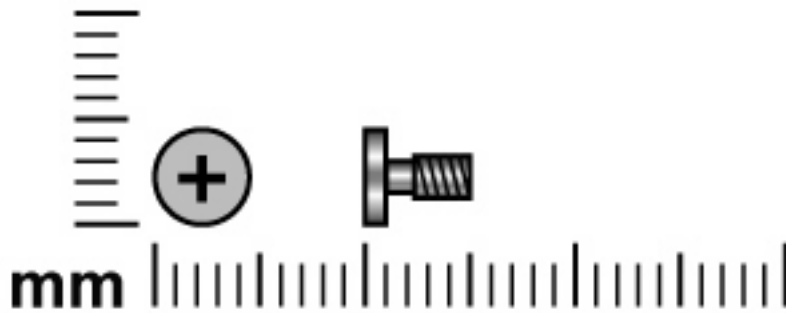

Color	Quantity	Length	Thread	Head diameter
Black	11	5.0 mm	2.0 mm	4.5 mm

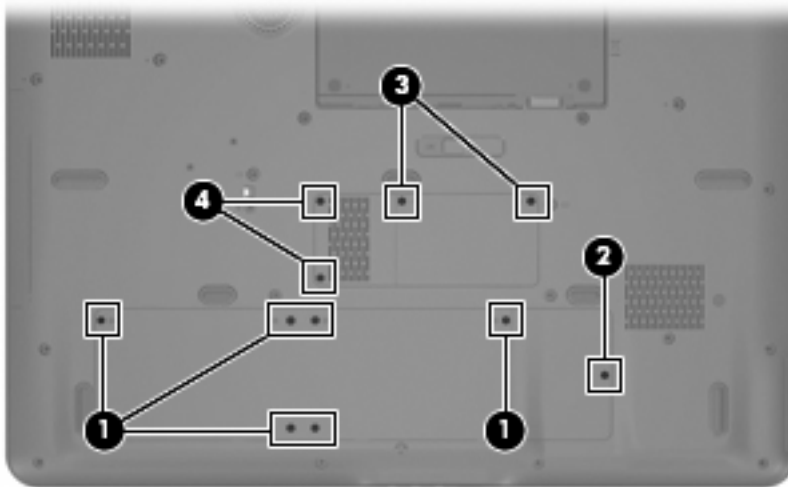

### Where used:

- (1)** Six captive screws (secured by C-clips) that secure the hard drive bay cover to the computer
- (2)** One captive screw (secured by a C-clip) that secure the WLAN module compartment cover to the computer
- (3)** Two captive screws (secured by C-clips) that secure the memory module compartment cover to the computer
- (4)** Two captive screws (secured by C-clips) that secure the TV tuner module compartment cover to the computer

## Phillips PM2.5×12.0 captive screw

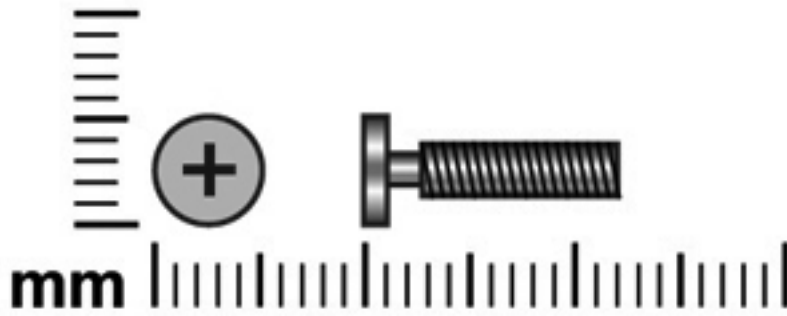

Color	Quantity	Length	Thread	Head diameter
Silver	2	12.0 mm	2.5 mm	5.0 mm

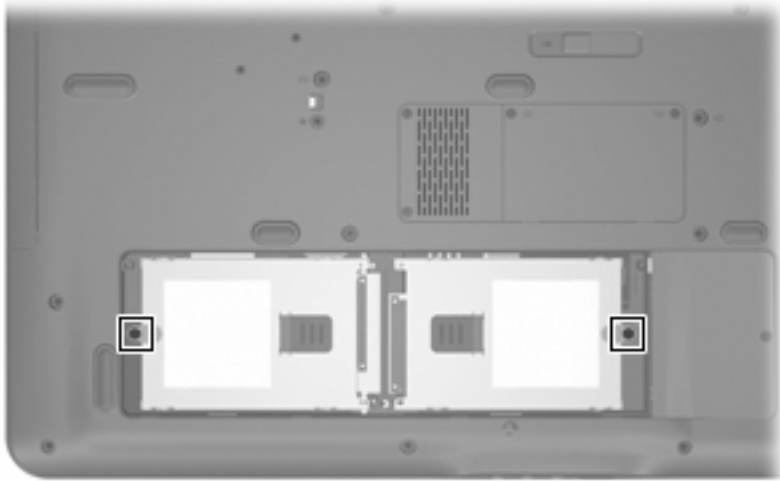

**Where used:** 2 captive screws (secured by C-clips) that secure the hard drives to the computer

## Phillips PM3.0×4.0 screw

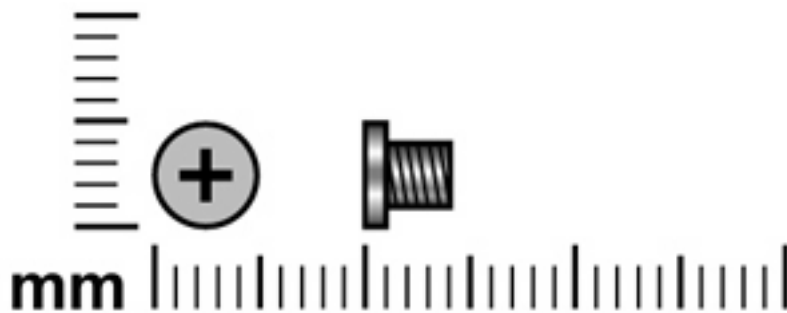

Color	Quantity	Length	Thread	Head diameter
Silver	8	4.0 mm	3.0 mm	5.0 mm

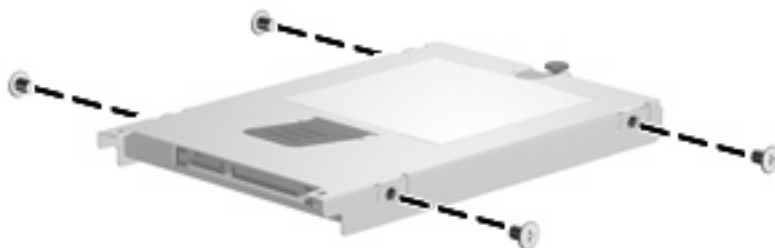

**Where used:** 8 screws that secure the hard drive brackets to the two hard drives

## Phillips PM2.5×8.0 screw

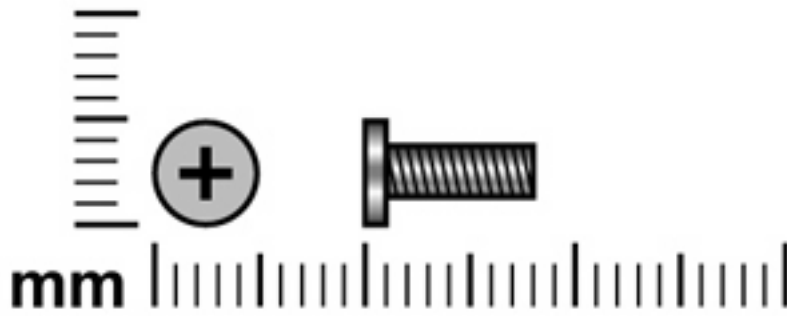

Color	Quantity	Length	Thread	Head diameter
Black	26	8.0 mm	2.5 mm	5.0 mm

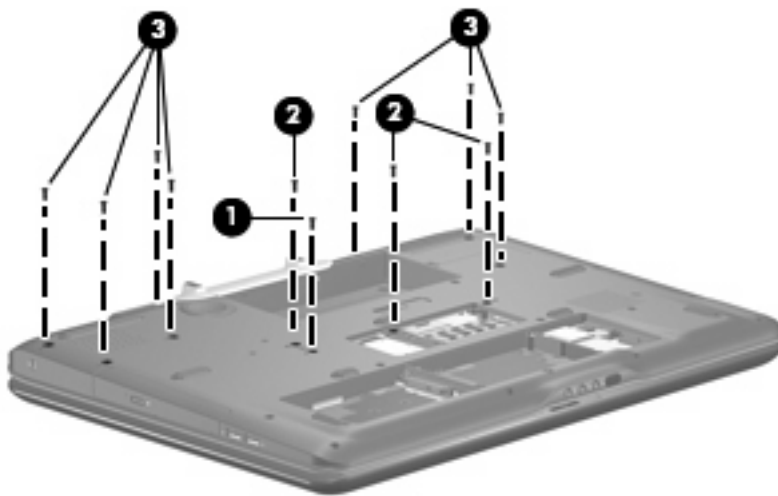

### Where used:

- (1) One screw that secures the optical drive to the computer
- (2) Three screws that secure the keyboard to the computer
- (3) Seven screws that secure the rear cover to the computer

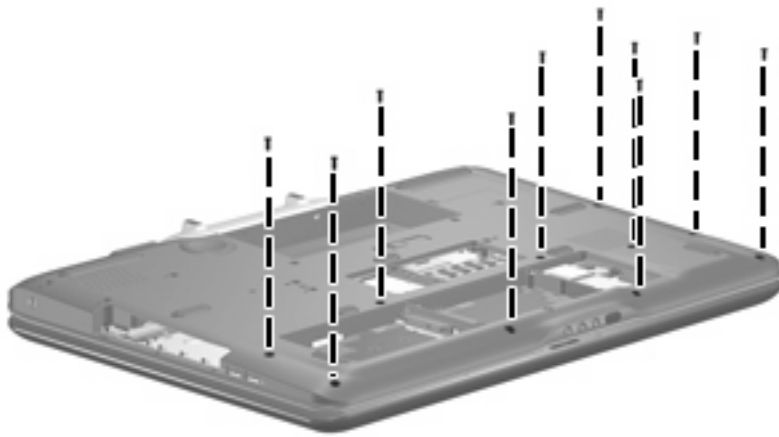

**Where used:** 10 screws that secure the top cover to the computer

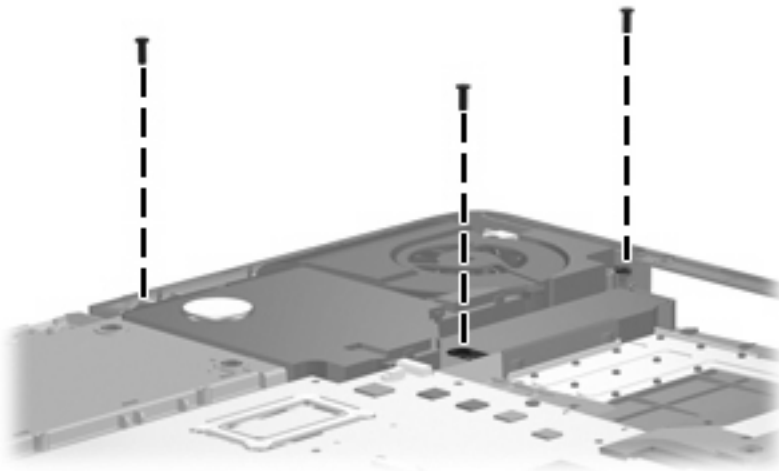

**Where used:** 3 screws that secure the subwoofer to the base enclosure

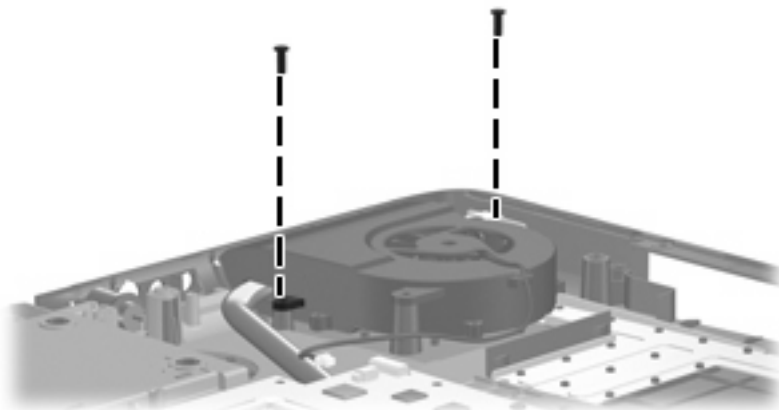

**Where used:** 2 screws that secure the processor fan to the base enclosure

## Phillips PM2.0×3.0 screw

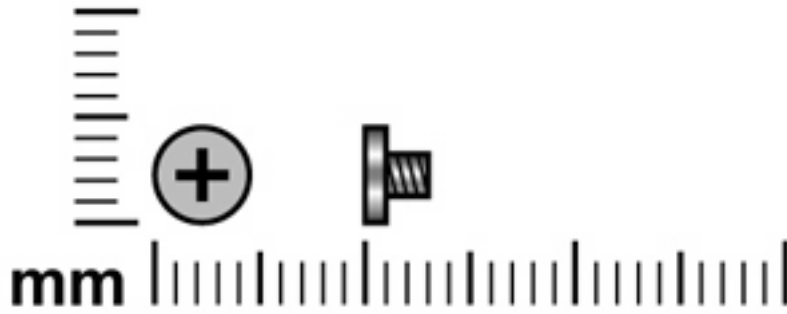

Color	Quantity	Length	Thread	Head diameter
Silver	2	3.0 mm	2.0 mm	4.5 mm

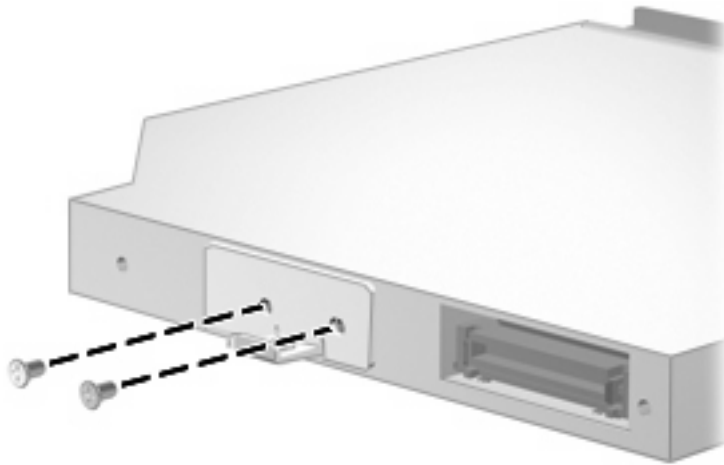

**Where used:** 2 screws that secure the optical drive bracket to the optical drive

## Phillips PM3.0x8.0 screw

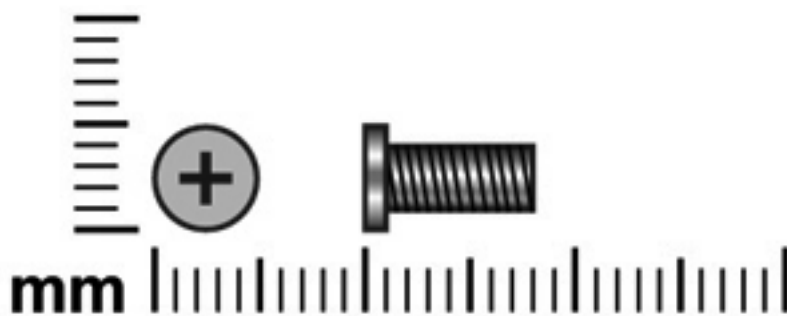

Color	Quantity	Length	Thread	Head diameter
Black	16	8.0 mm	3.0 mm	5.0 mm

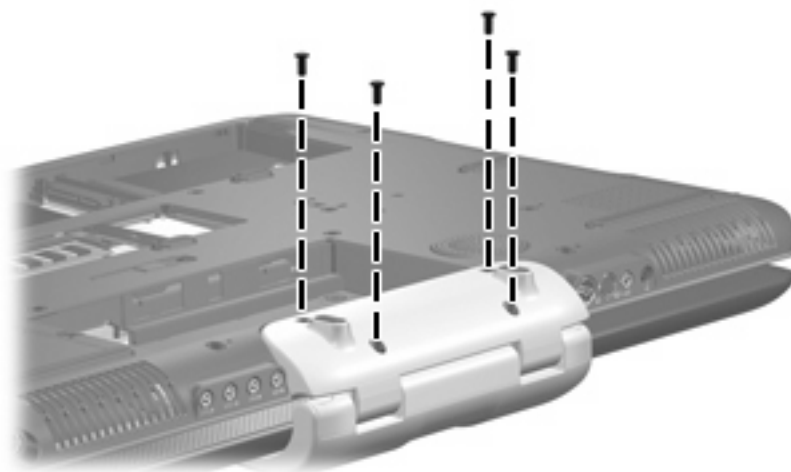

**Where used:** 4 screws that secure the hinge cover to the computer

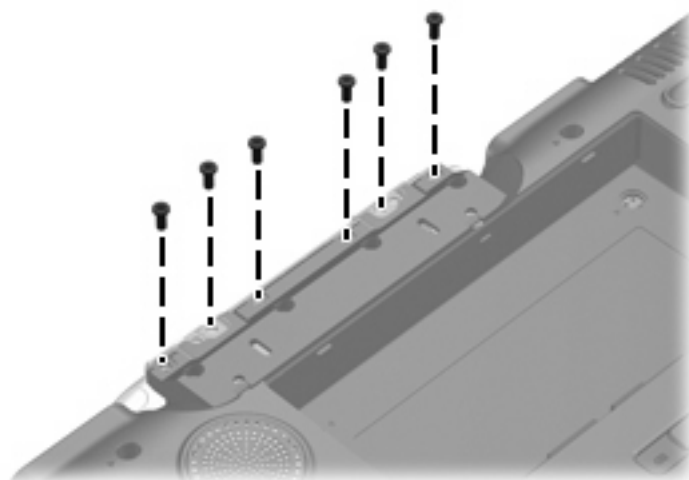

**Where used:** 6 screws that secure the display assembly to the computer

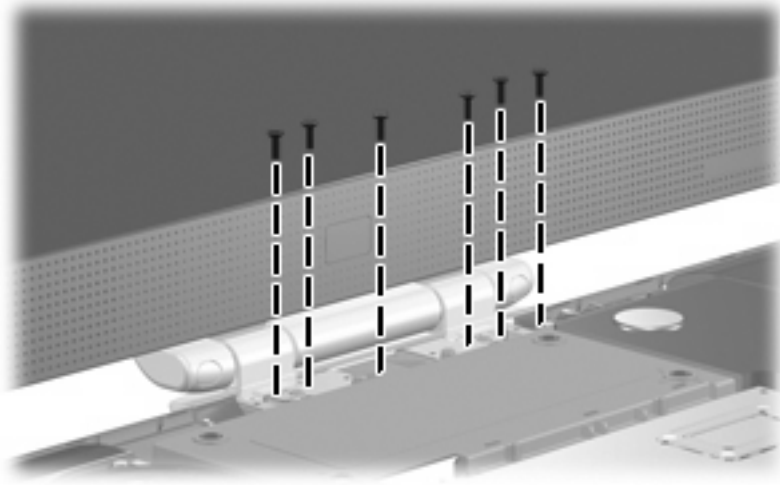

**Where used:** 6 screws that secure the display assembly to the computer



## Phillips PM2.5×4.0 screw

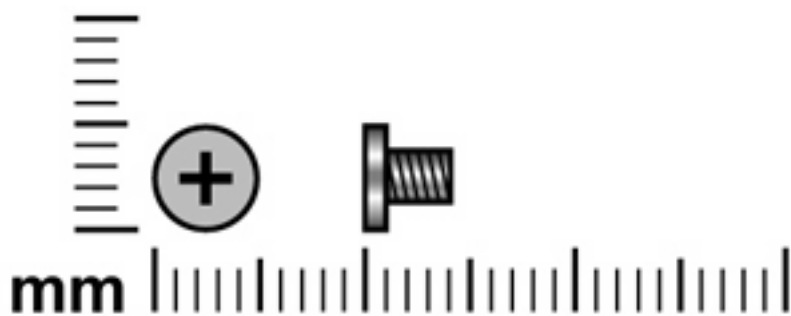

Color	Quantity	Length	Thread	Head diameter
Black	8	4.0 mm	2.5 mm	5.0 mm

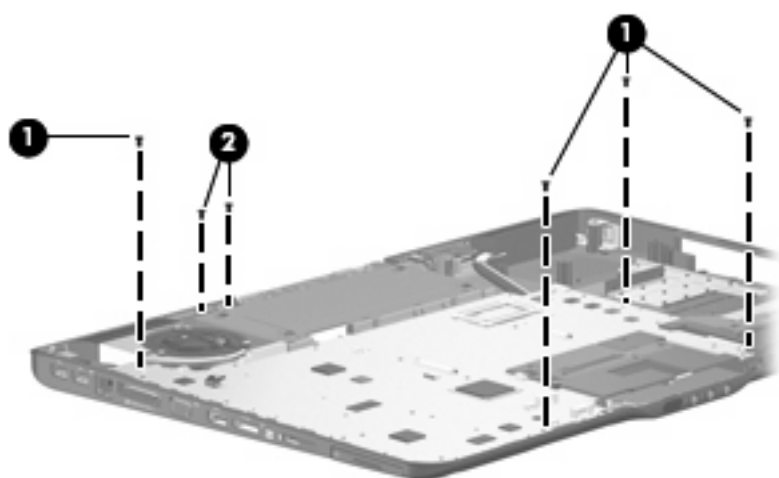

### Where used:

(1) Four screws that secure the system board to the base enclosure

(2) Two screws that secure the audio connector board to the base enclosure

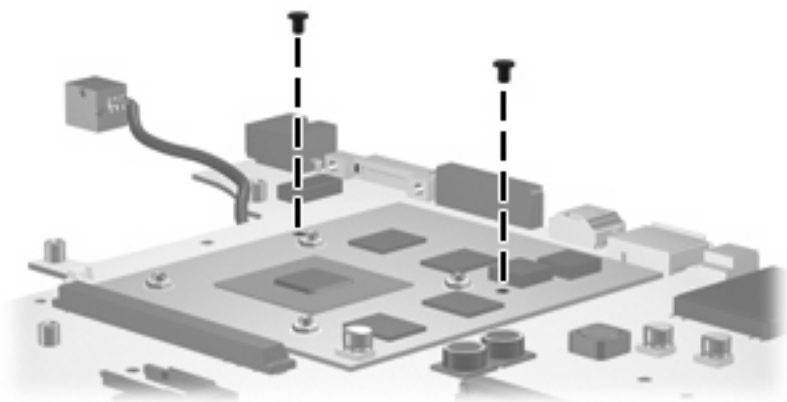

**Where used:** 2 screws that secure the video board to the system board

## Phillips PM3.0×12.0 screw

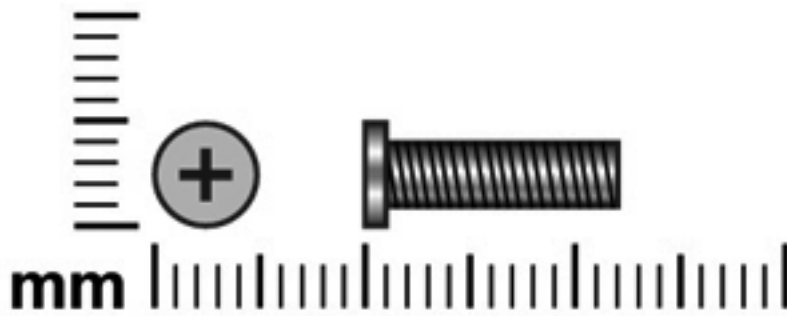

Color	Quantity	Length	Thread	Head diameter
Black	4	12.0 mm	3.0 mm	5.0 mm

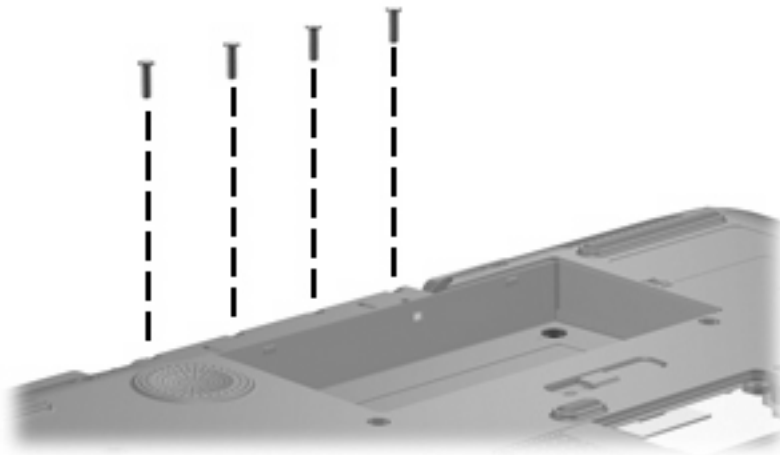

**Where used:** 4 screws that secure the rear cover to the computer

## Phillips 2.5×3.0 broad-head screw

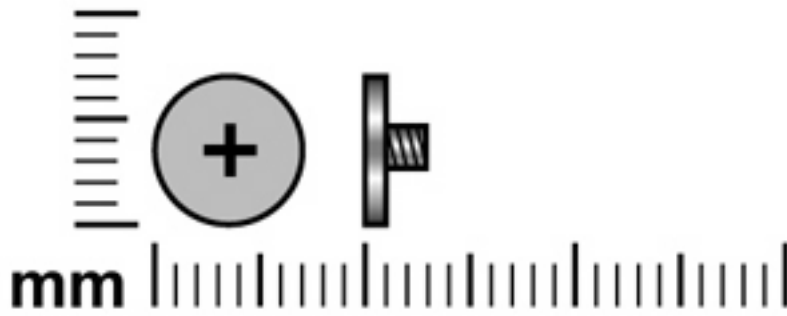

Color	Quantity	Length	Thread	Head diameter
Black	4	3.0 mm	2.5 mm	7.0 mm

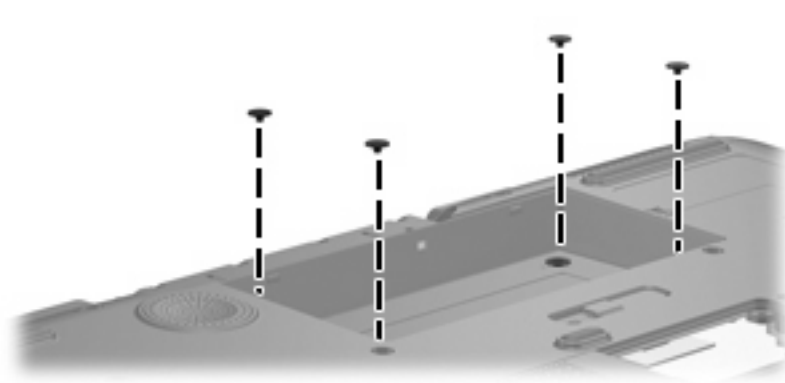

**Where used:** 4 screws that secure the rear cover to the computer

## Phillips PM2.5×1 1.0 screw

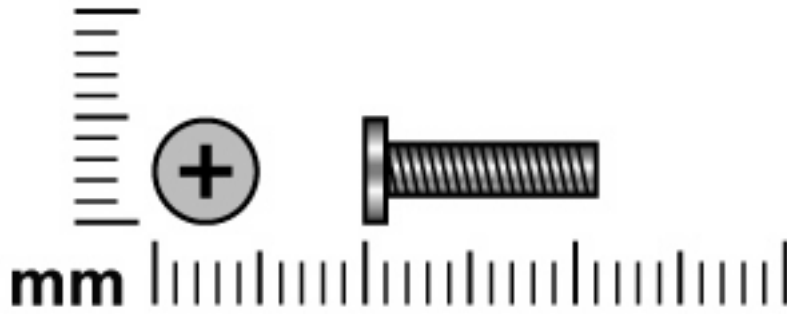

Color	Quantity	Length	Thread	Head diameter
Black	2	11.0 mm	2.5 mm	5.0 mm

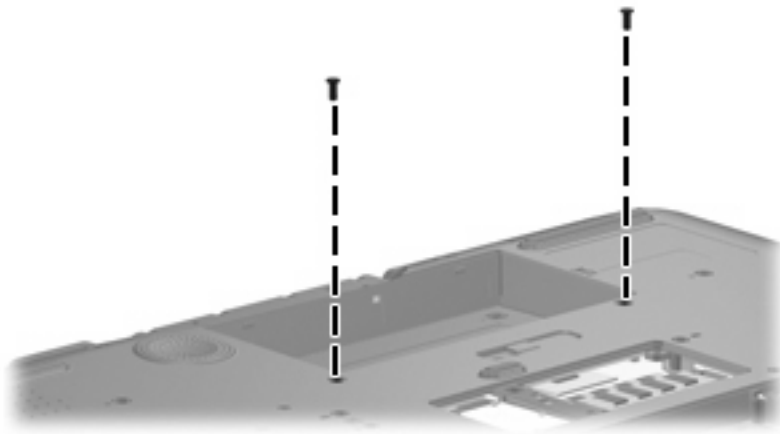

**Where used:** 2 screws that secure the top cover to the computer

## Silver Phillips PM2.0×4.0 screw

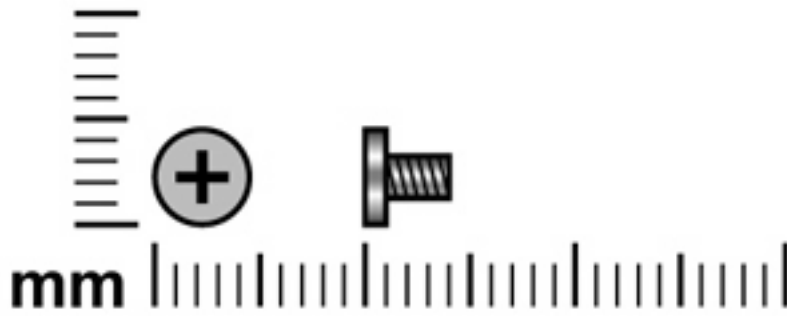

Color	Quantity	Length	Thread	Head diameter
Silver	6	4.0 mm	2.0 mm	4.5 mm

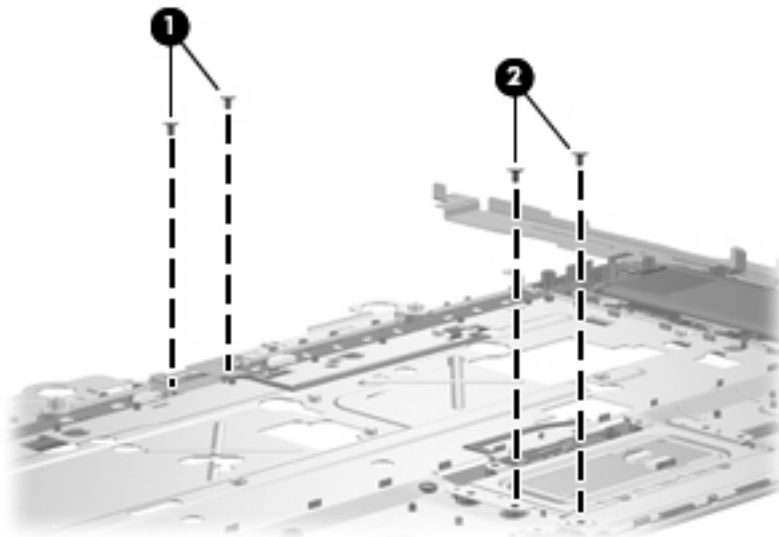

### Where used:

- (1) Two screws that secure the fingerprint reader board to the top cover
- (2) Two screws that secure the TouchPad on/off board to the top cover

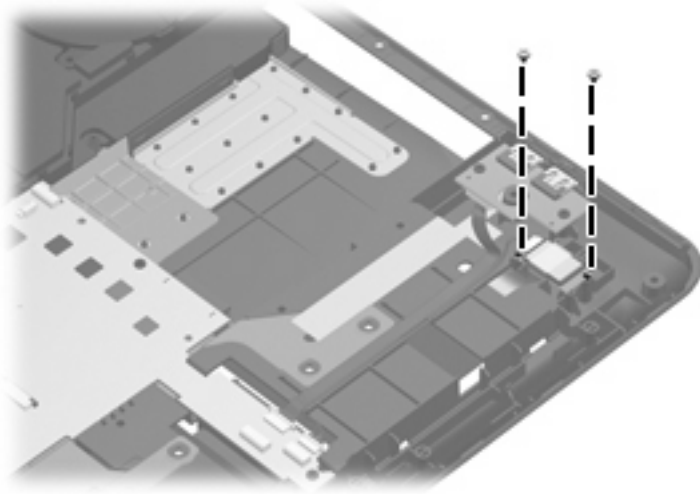

**Where used:** 2 screws that secure the Bluetooth module to the base enclosure

## Slotted SM1.5×9.0 shoulder screw

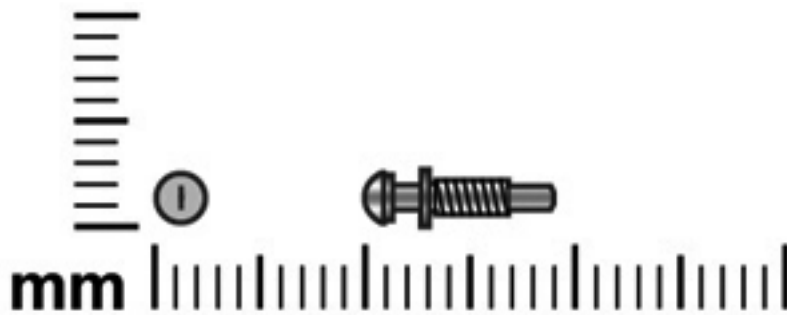

Color	Quantity	Length	Thread	Head diameter
Silver	2	9.0 mm	1.5 mm	1.5 mm



**Where used:** 2 screws that secure the system board to the base enclosure

## Phillips PM2.5×13.0 captive screw

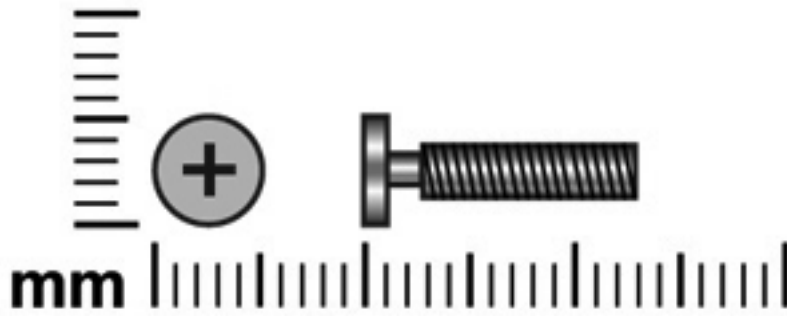

Color	Quantity	Length	Thread	Head diameter
Silver	1	13.0 mm	2.5 mm	5.0 mm

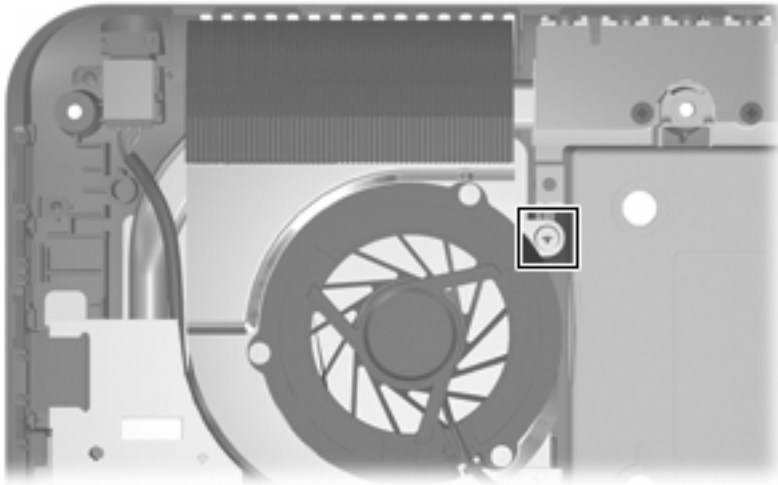

**Where used:** One captive screw (secured inside the video heat sink) that secures the system board and video board heat sink to the base enclosure



## Silver Phillips PM2.0x5.0 captive screw

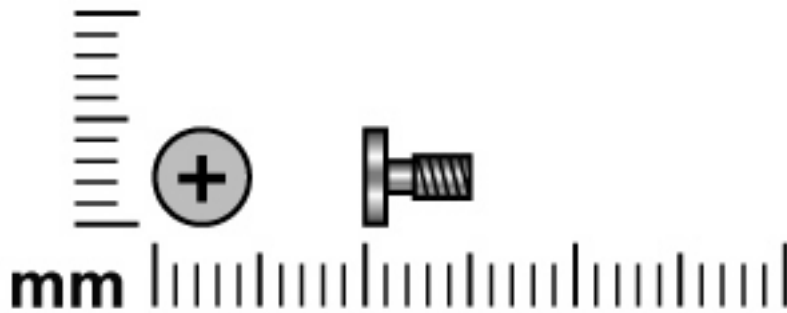

Color	Quantity	Length	Thread	Head diameter
Silver	7	5.0 mm	2.0 mm	4.5 mm

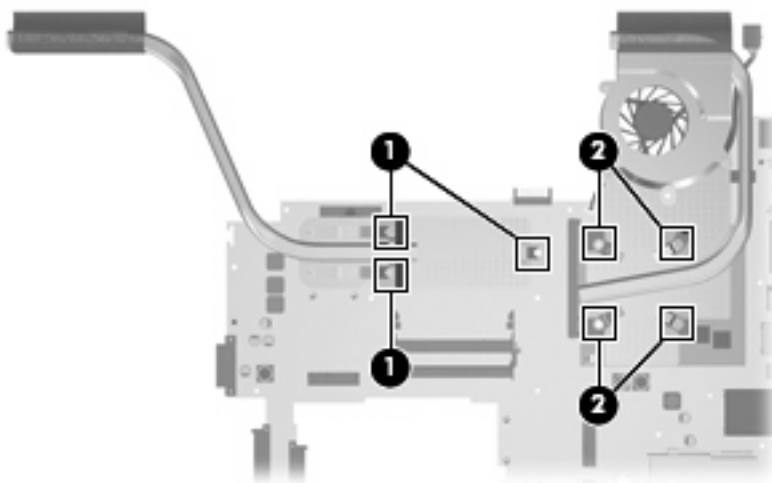

### Where used:

- (1) Three captive screws (secured by C-clips) that secure the processor heat sink to the system board
- (2) Four captive screws (secured by C-clips) that secure the video board heat sink to the system board

## Phillips PM2.5×8.0 captive screw

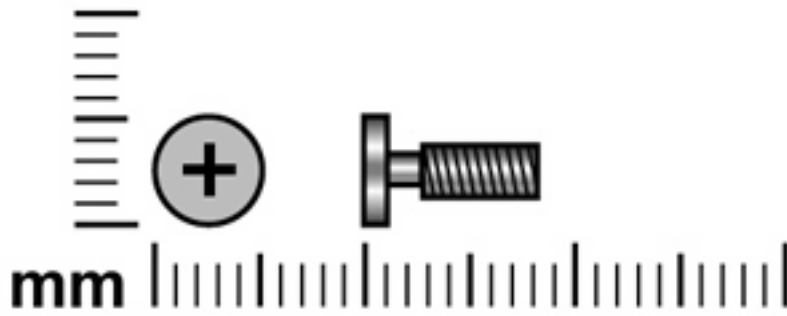

Color	Quantity	Length	Thread	Head diameter
Silver	2	8.0 mm	2.5 mm	5.0 mm

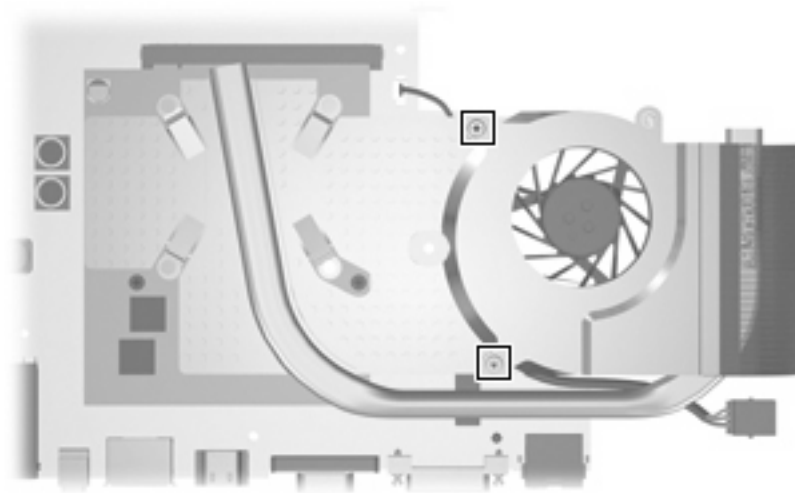

**Where used:** 2 captive screws (secured inside the video board heat sink) that secure the video board heat sink to the system board

## Black Phillips PM2.0×4.0 screw

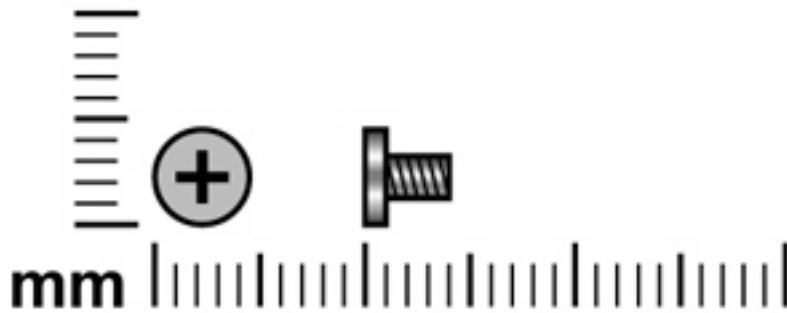

Color	Quantity	Length	Thread	Head diameter
Black	3	4.0 mm	2.0 mm	4.5 mm

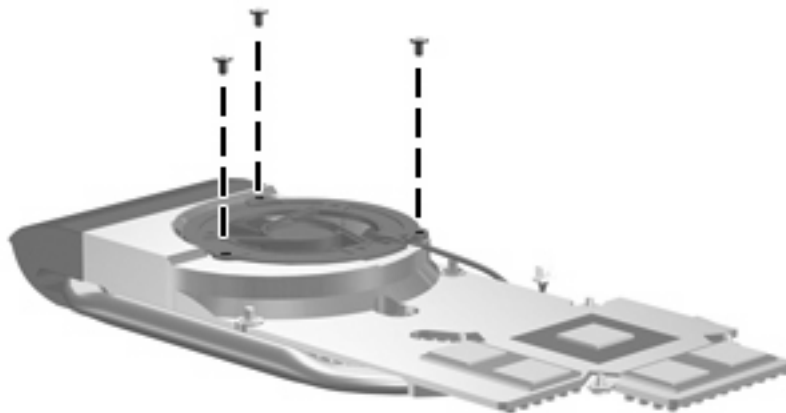

**Where used:** 3 screws that secure the video board fan to the video board heat sink

---

# 8 Backup and Recovery

## Recovering system information

Tools provided by the operating system and Recovery Manager software are designed to help you with the following tasks for safeguarding your information and restoring it in case of a system failure:

- Backing up your information regularly to protect your important system files.
- Making a set of recovery discs (Recovery Manager software feature). Recovery discs are used to start up (boot) your computer and restore the operating system and software programs to factory settings in case of system failure or instability.
- Creating system restore points (operating system feature). System restore points allow you to reverse undesirable changes to your computer by restoring the computer to an earlier state.
- Recovering a program or driver (Recovery Manager software feature). This feature helps you reinstall a program or driver without performing a full system recovery.
- Performing a full system recovery (Recovery Manager software feature). With Recovery Manager, you can recover your full factory image if you experience system failure or instability. Recovery Manager works from a dedicated recovery partition on the hard drive or from recovery discs you create. Back up your information regularly to protect your important system files.

## Creating recovery discs

After setting up the computer for the first time, be sure to create a set of recovery discs of the full factory image. The recovery discs are used to start up (boot) the computer and recover the operating system and software to factory settings in case of system instability or failure.

---

 **NOTE:** Handle these discs carefully and keep them in a safe place. The software allows the creation of only one set of recovery discs.

---

Note the following guidelines before creating recovery discs:

- You will need high quality CD-R, DVD-R, DVD-R with double-layer support, DVD+R, or DVD+R with double-layer support discs (purchased separately).

---

 **NOTE:** Read-write discs, such as CD-RW, DVD  $\pm$  RW, and DVD $\pm$ RW double-layer discs, are not compatible with the Recovery Manager software.

---

- The computer must be connected to AC power during this process.
- Only one set of recovery discs can be created per computer.

- Number each disc before inserting it into the computer optical drive.
- If necessary, you can exit the program before you have finished creating the recovery discs. The next time you open Recovery Manager, you will be prompted to continue the disc creation process.

To create a set of recovery discs:

1. Select **Start > All Programs > Recovery Manager > Recovery Manager**.

Recovery Manager opens.

2. Click **Advanced Options**.

---

 **NOTE:** If you are operating the computer on battery power, you will be prompted to connect to AC power before you can go to the next step.

---

3. Click **Recovery disc creation**, and then click **Next**.
4. Follow the on-screen instructions.

## Backing up your information

### When to back up

- On a regularly scheduled basis

---

 **NOTE:** Set reminders to back up your information periodically.

---

- Before the computer is repaired or restored
- Before you add or modify hardware or software

## Back up suggestions

- Create a set of recovery discs using Recovery Manager.
- Create system restore points using the Windows System Restore feature, and periodically copy them to disc.
- Store personal files in the Documents folder and back up these folders periodically.
- Back up templates stored in their associated programs.
- Save customized settings in a window, toolbar, or menu bar by taking a screen shot of your settings. The screen shot can be a time saver if you have to reset your preferences.

To copy the screen and paste it into a word-processing document follow these steps:

- a. Display the screen.
- b. Copy the screen:  
To copy only the active screen, press **alt+fn+prt sc**.  
To copy the entire screen, press **fn+prt sc**.
- c. Open a word-processing document, and then select **Edit > Paste**.

## Using system restore points

When you back up your system, you are creating a system restore point. A system restore point allows you to save and name a snapshot of your hard drive at a specific point in time. You can then recover back to that point if you want to reverse subsequent changes made to your system.

---

 **NOTE:** Recovering to an earlier restore point does not affect data files saved or e-mails created since the last restore point.

---

You also can create additional restore points to provide increased protection for your system files and settings.

## When to create restore points

- Before you add or extensively modify software or hardware
- Periodically, whenever the system is performing optimally

---

 **NOTE:** If you revert to a restore point and then change your mind, you can reverse the restoration.

---

## Create a system restore point

1. Select **Start > Control Panel > System and Maintenance > System**.
2. In the left pane, click **System protection**.
3. Click the **System Protection** tab.
4. Under **Automatic restore points**, select the disk for which you want to create a restore point.
5. Click **Create**.

The System Protection window opens.

6. Follow the on-screen instructions.

## Restore to a previous date and time

To revert to a restore point (created at a previous date and time), when the computer was functioning optimally, follow these steps:

1. Select **Start > Control Panel > System and Maintenance > System**.
2. In the left pane, click **System protection**.
3. Click the **System Protection** tab.
4. Click the **System Restore** button, and then click **Next**.

The System Restore window opens.

5. Follow the on-screen instructions.



## Performing a recovery

Recovery Manager software allows you to repair or restore the system if you experience system failure or instability. Recovery Manager works from recovery discs that you create or from a dedicated recovery partition on the hard drive.

 **NOTE:** Windows has its own built-in repair features, such as System Restore and driver roll-back capabilities. If you have not already tried these features, try them before using Recovery Manager.

**NOTE:** Recovery Manager recovers only software that was preinstalled at the factory. Software not provided with this computer must be downloaded from the manufacturer's Web site or reinstalled from the disc provided by the manufacturer.

## Recovering from the recovery discs

To restore the system from the recovery discs:

1. Back up all personal files.
2. Insert the first recovery disc into the optical drive and restart the computer.
3. Follow the on-screen instructions.

## Recovering from the partition on the hard drive

You can perform a recovery from the partition on the hard drive from either the Start button or **f11**.

To restore the system from the partition, follow these steps:

1. Access Recovery Manager in either of the following ways:
  - Select **Start > All Programs > Recovery Manager > Recovery Manager**.
  - or–
  - Restart the computer and press **f11** while the “Press <F11> for recovery” message is displayed on the screen. Then select **Recovery Manager**.

Recovery Manager opens.

2. Click **Advanced Options**.
3. Click **System recovery**, and then click **Next**.
4. Follow the on-screen instructions.

## 9 Connector pin assignments

### Audio-out (headphone)

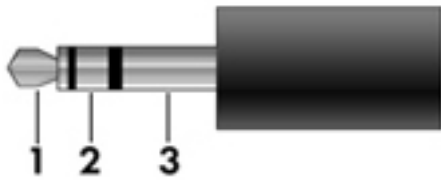

Pin	Signal
1	Audio out, left channel
2	Audio out, right channel
3	Ground

### Audio-in (microphone)

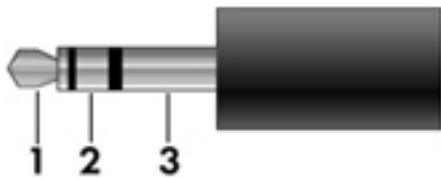

Pin	Signal
1	Audio signal in
2	Audio signal in
3	Ground

## External monitor

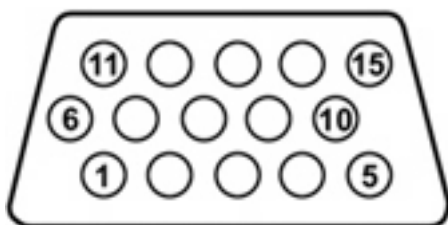

Pin	Signal
1	Red analog
2	Green analog
3	Blue analog
4	Not connected
5	Ground
6	Ground analog
7	Ground analog
8	Ground analog
9	+5 VDC
10	Ground
11	Monitor detect
12	DDC 2B data
13	Horizontal sync
14	Vertical sync
15	DDC 2B clock

## RJ-45 (network)

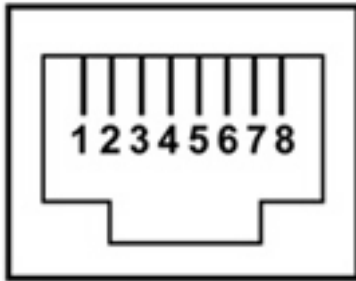

Pin	Signal
1	Transmit +
2	Transmit -
3	Receive +
4	Unused
5	Unused
6	Receive -
7	Unused
8	Unused

# Universal Serial Bus

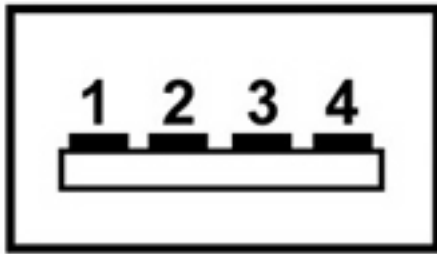

Pin	Signal
1	+5 VDC
2	Data -
3	Data +
4	Ground

---

# 10 Power cord set requirements

The wide range input feature of the computer permits it to operate from any line voltage from 100 to 120 volts AC or from 220 to 240 volts AC.

The 3-conductor power cord set included with the computer meets the requirements for use in the country or region where the equipment is purchased.

Power cord sets for use in other countries or regions must meet the requirements of the country or region where the computer is used.

## Requirements for all countries or regions

The requirements listed below are applicable to all countries or regions:

- The length of the power cord set must be at least 1.5 m (5.0 ft) and no more than 2.0 m (6.5 ft).
- All power cord sets must be approved by an acceptable accredited agency responsible for evaluation in the country or region where the power cord set will be used.
- The power cord sets must have a minimum current capacity of 10 amps and a nominal voltage rating of 125 or 250 V AC, as required by each country or region's power system.
- The appliance coupler must meet the mechanical configuration of an EN 60 320/IEC 320 Standard Sheet C13 connector for mating with the appliance inlet on the back of the computer.

# Requirements for specific countries or regions

Country or region	Accredited agency	Applicable note number
Australia	EANSW	1
Austria	OVE	1
Belgium	CEBC	1
Canada	CSA	2
Denmark	DEMKO	1
Finland	FIMKO	1
France	UTE	1
Germany	VDE	1
Italy	IMQ	1
Japan	METI	3
South Korea	EK	4
The Netherlands	KEMA	1
Norway	NEMKO	1
The People's Republic of China	CCC	5
Sweden	SEMKO	1
Switzerland	SEV	1
Taiwan	BSMI	4
The United Kingdom	BSI	1
The United States	UL	2

1. The flexible cord must be Type HO5VV-F, 3-conductor, 1.0-mm<sup>2</sup> conductor size. Power cord set fittings (appliance coupler and wall plug) must bear the certification mark of the agency responsible for evaluation in the country or region where it will be used.
2. The flexible cord must be Type SPT-3 or equivalent, No. 18 AWG, 3-conductor. The wall plug must be a two-pole grounding type with a NEMA 5-15P (15 A, 125 V) or NEMA 6-15P (15 A, 250 V) configuration.
3. The appliance coupler, flexible cord, and wall plug must bear a "T" mark and registration number in accordance with the Japanese Dentori Law. The flexible cord must be Type VCT or VCTF, 3-conductor, 1.00-mm<sup>2</sup> conductor size. The wall plug must be a two-pole grounding type with a Japanese Industrial Standard C8303 (7 A, 125 V) configuration.
4. The flexible cord must be Type RVV, 3-conductor, 0.75-mm<sup>2</sup> conductor size. Power cord set fittings (appliance coupler and wall plug) must bear the certification mark of the agency responsible for evaluation in the country or region where it will be used.
5. The flexible cord must be Type VCTF, 3-conductor, 0.75-mm<sup>2</sup> conductor size. Power cord set fittings (appliance coupler and wall plug) must bear the certification mark of the agency responsible for evaluation in the country or region where it will be used.

---

# 11 Recycling

## Battery

When a battery has reached the end of its useful life, do not dispose of the battery in general household waste. Follow the local laws and regulations in your area for computer battery disposal.

## Display

- ⚠ **WARNING!** The backlight contains mercury. Caution must be exercised when removing and handling the backlight to avoid damaging this component and causing exposure to the mercury.
- ⚠ **CAUTION:** The procedures in this appendix can result in damage to display components. The only components intended for recycling purposes are the liquid crystal display (LCD) panel and the backlight. Careful handling must be exercised when removing these components.
- 📄 **NOTE: Materials Disposal.** This HP product contains mercury in the backlight in the display assembly that might require special handling at end-of-life. Disposal of mercury may be regulated because of environmental considerations. For disposal or recycling information, contact your local authorities, or see the Electronic Industries Alliance (EIA) Web site at <http://www.eiae.org>.

This section provides disassembly instructions for the display assembly. The display assembly must be disassembled to gain access to the backlight **(1)** and the liquid crystal display (LCD) panel **(2)**.



- 📄 **NOTE:** The procedures provided in this appendix are general disassembly instructions. Specific details, such as screw sizes, quantities, and locations, and component shapes and sizes, can vary from one computer model to another.



Perform the following steps to disassemble the display assembly:

1. Remove all screw covers **(1)** and screws **(2)** that secure the display bezel to the display assembly.

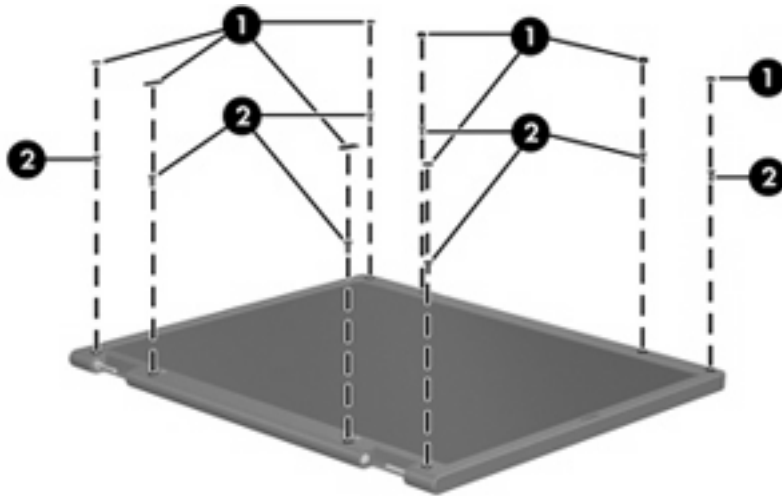

2. Lift up and out on the left and right inside edges **(1)** and the top and bottom inside edges **(2)** of the display bezel until the bezel disengages from the display assembly.
3. Remove the display bezel **(3)**.

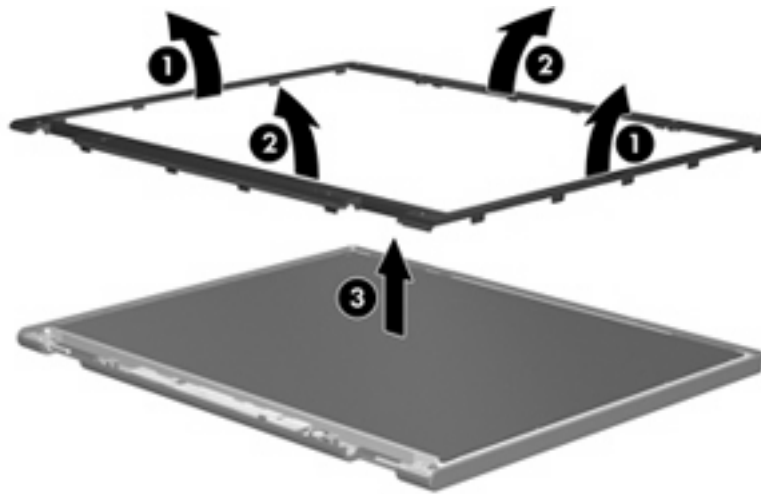

4. Disconnect all display panel cables **(1)** from the display inverter and remove the inverter **(2)**.

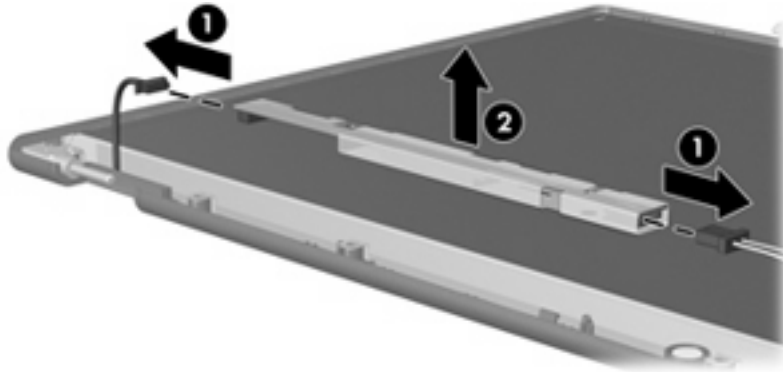

5. Remove all screws **(1)** that secure the display panel assembly to the display enclosure.
6. Remove the display panel assembly **(2)** from the display enclosure.

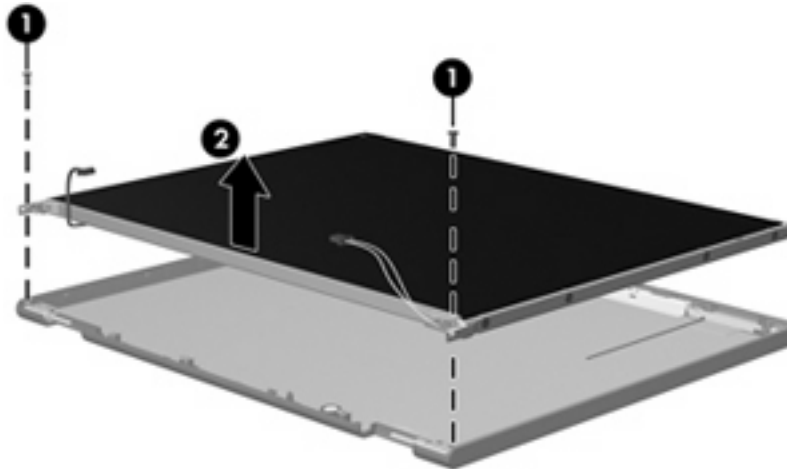

7. Turn the display panel assembly upside down.
8. Remove all screws that secure the display panel frame to the display panel.

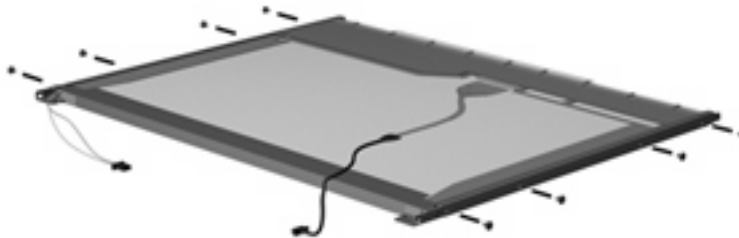

9. Use a sharp-edged tool to cut the tape **(1)** that secures the sides of the display panel to the display panel frame.

10. Remove the display panel frame **(2)** from the display panel.

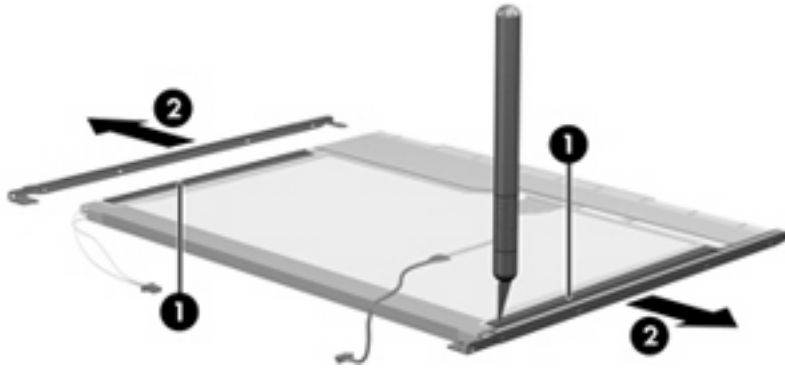

11. Remove the screws **(1)** that secure the backlight cover to the display panel.
12. Lift the top edge of the backlight cover **(2)** and swing it outward.

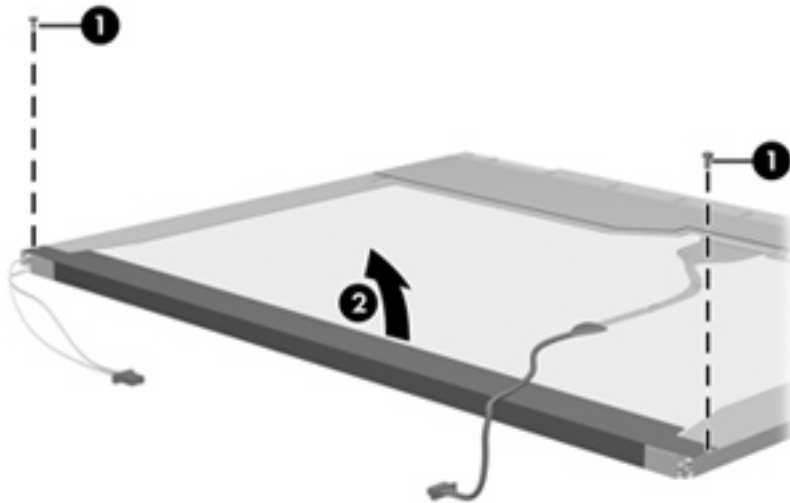

13. Remove the backlight cover.
14. Turn the display panel right-side up.

15. Remove the backlight cables (1) from the clip (2) in the display panel.

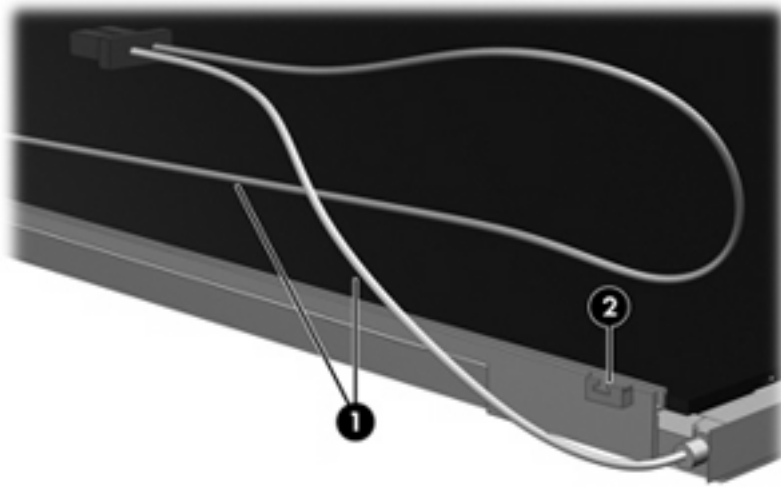

16. Turn the display panel upside down.
17. Remove the backlight frame from the display panel.

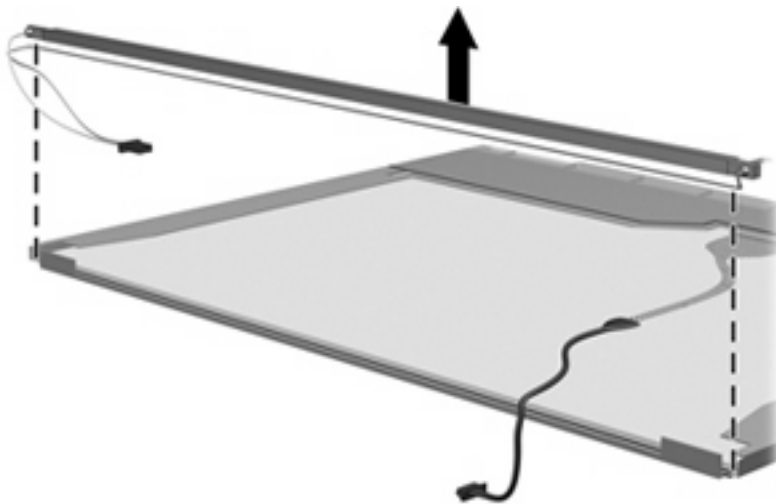

**⚠ WARNING!** The backlight contains mercury. Exercise caution when removing and handling the backlight to avoid damaging this component and causing exposure to the mercury.

18. Remove the backlight from the backlight frame.

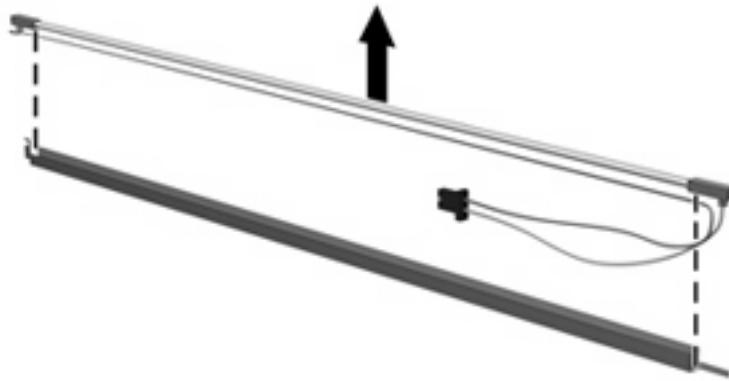

19. Disconnect the display cable (1) from the LCD panel.
20. Remove the screws (2) that secure the LCD panel to the display rear panel.
21. Release the LCD panel (3) from the display rear panel.
22. Release the tape (4) that secures the LCD panel to the display rear panel.

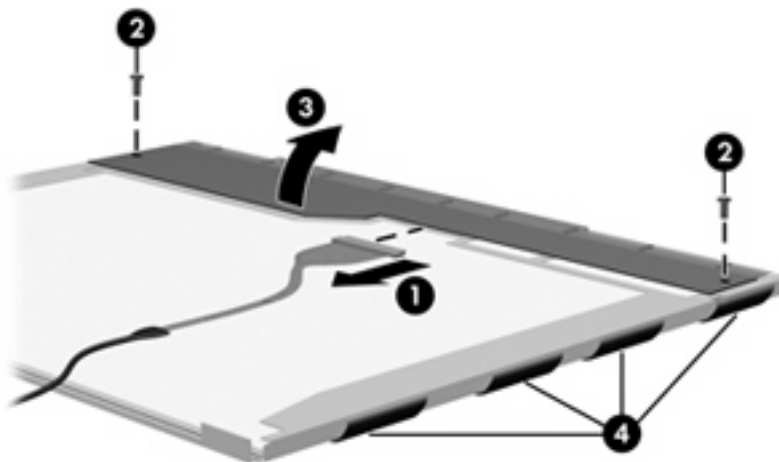

23. Remove the LCD panel.

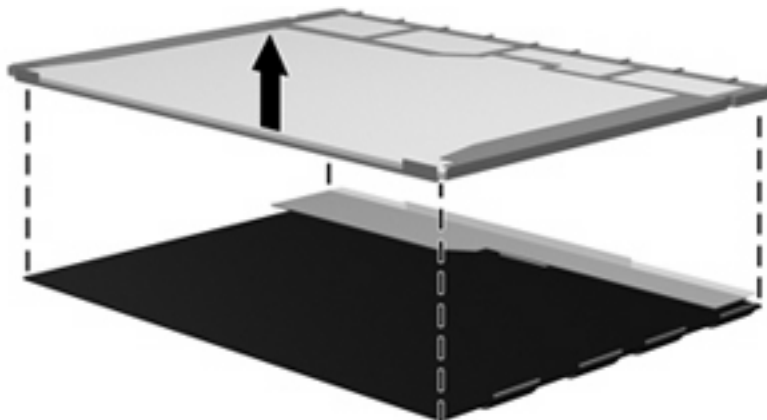

24. Recycle the LCD panel and backlight.

# Index

## Symbols/Numerics

1394 port 16

## A

AC adapter, spare part  
number 26, 28  
analog channel output jack 14  
audio connector board  
removal 80  
spare part number 20, 30,  
80  
audio, product description 2  
audio-in jack  
location 12  
pin assignments 138  
audio-out jack  
location 12  
pin assignments 138  
audio/infrared board  
removal 67  
spare part number 20, 30,  
67

## B

backup 133  
base enclosure, spare part  
number 21, 29  
bass light 10  
battery  
removal 38  
spare part number 22, 28,  
38  
battery bay 17  
battery light 12  
battery release latch 17  
Bluetooth module  
removal 68  
spare part number 21, 27,  
68  
boot options 97

boot order 97  
bottom components 17  
button components 7, 9  
buttons  
DVD 8  
media 7  
next/fast forward 8  
optical drive 9  
play/pause 8  
power 7  
previous/rewind 8  
remote control 8  
stop 8  
theater mode 8  
treble/bass 10  
TV play 8  
volume mute 9  
wireless 9

## C

Cable Kit, spare part number 22,  
29  
cables, service considerations 32  
camera  
location 6  
product description 2  
camera light 6  
camera module  
illustrated 23  
removal 42  
spare part number 23, 29,  
42  
camera rotator 7  
caps lock light 8  
changing the language in Computer  
Setup 93  
chipset, product description 1  
closing Computer Setup 94  
CMOS clearing 36

components  
bottom 17  
buttons 7, 9  
display 6  
fingerprint reader 9  
front 12  
keys 11  
left-side 16  
lights 7, 9  
pointing device 10  
rear 13  
right-side 15  
top 6  
TouchPad 10  
composite video cable, spare part  
number 26  
computer feet  
locations 39  
spare part number 21, 30,  
39  
Computer Setup  
accessing 92  
changing the language 93  
closing 94  
Diagnostics menu 96  
File menu 95  
navigating and selecting 93  
restoring default settings 94  
Security menu 96  
System Configuration menu 97  
using 93  
computer specifications 98  
connectors  
power 14  
service considerations 32

## D

device configurations 97  
Diagnostics menu 96  
Digital Media Slot 16

- Digital Media Slot light 16
- diskette drive
  - precautions 32
  - product description 2
- display assembly
  - removal 64
  - spare part numbers 20, 29, 64
- display bezel
  - illustrated 23
  - removal 40
  - spare part number 23, 29, 42
- Display Bracket Kit, spare part number 23, 29
- display components
  - illustrated 23
  - recycling 144
- display hinge/enclosure
  - illustrated 23
  - spare part number 23
- display hinge/enclosure, spare part number 29
- display inverter
  - illustrated 23
  - spare part number 23, 29, 43
- display panel
  - illustrated 23
  - product description 1
  - removal 43
  - spare part numbers 23, 29, 44
- Display Rubber Pad Kit, spare part number 24, 30
- Display Screw Kit, spare part number 24, 30
- display specifications 99, 100
- display switch 7
- docking support, product description 5
- drive light 12
- drives
  - boot order 97
  - preventing damage 32
- DVB-T antenna adapter, spare part number 26
- DVB-T tuner, spare part number 26
- DVD button 8

- DVD±RW and CD-RW Combo Drive
  - precautions 32
  - removal 52
  - spare part number 22, 25, 28, 52
  - specifications 102

## E

- electrostatic discharge 33
- eSATA port 16
- esc key 11
- Ethernet, product description 2
- expansion port 3 port 16
- ExpressCard Kit, spare part number 26
- ExpressCard slot 16
- ExpressCard slot bezel 24
- external media cards, product description 3
- external monitor port
  - location 16
  - pin assignments 139

## F

- fan
  - removal 75, 89
  - spare part numbers 21, 29, 75, 89
- feet
  - locations 39
  - spare part number 21, 30, 39
- File menu 95
- fingerprint reader 9
- fingerprint reader board
  - removal 61
  - spare part number 20, 29, 61
- fn key 11
- front components 12
- front USB board
  - removal 69
  - spare part number 21, 30, 69
- function keys 11

## G

- graphics, product description 1
- grounding equipment and methods 35

## H

- hard drive
  - precautions 32
  - product description 1
  - removal 45
  - spare part numbers 22, 25, 28, 30, 45
  - specifications 101
- hard drive bay 17
- hard drive bay cover
  - illustrated 24
  - removal 45
- hard drive test 96
- HD-DVD Drive
  - precautions 32
  - removal 52
  - spare part number 22, 25, 28, 52
- HDMI port, location 16
- headphone jack
  - location 12
  - pin assignments 138
- headset, spare part numbers 26, 27, 28
- heat sink
  - removal 83, 87
  - spare part numbers 21, 29, 83, 87
- hinge cover
  - removal 56
  - spare part number 21, 30, 56
- HP Webcam light 6
- HP Webcam rotator 7
- HP Webcam 6

## I

- I/O address specifications 105
- infrared emitter, spare part number 26
- infrared lens 12
- interrupt specifications 104
- inverter
  - illustrated 23
  - spare part number 23, 29
- IR emitter jack 13

## J

- jacks
  - analog channel output 14

- analog channel output
    - jack 14
  - audio-in 12
  - audio-out 12
  - headphone 12
  - IR emitter 13
  - microphone 12
  - network 16
  - RF coaxial cable jack 13
  - RJ-45 16
  - S-Video-in 13
  - subwoofer analog channel
    - output 14
  - TV audio line-in 13
- K**
- key components 11
  - keyboard
    - product description 5
    - removal 54
    - spare part numbers 20, 28, 54
  - keypad keys 11
  - keys
    - esc 11
    - fn 11
    - function 11
    - keypad 11
    - Windows application 11
    - Windows logo 11
- L**
- language, changing in Computer Setup 97
  - left-side components 16
  - light components 7, 9
  - lights
    - bass 10
    - battery 12
    - caps lock 8
    - drive 12
    - num lock 10
    - optical drive 9
    - power 7, 12
    - treble 10
    - treble or bass volume down 9
    - treble or bass volume up 9
    - volume 9
    - volume down 9
  - volume mute 9
  - wireless 9
- M**
- mass storage devices, spare part numbers 25
  - media button 7
  - memory check 96
  - memory map specifications 107
  - memory module
    - product description 1
    - removal 50
    - spare part numbers 22, 28, 30, 50
  - memory module compartment 17
  - memory module compartment cover
    - illustrated 24
    - removal 51
  - microphone 6
  - microphone jack
    - location 12
    - pin assignments 138
  - Mini Card compartment 17
  - model name 1
  - modem, product description 2
  - monitor port
    - location 16
    - pin assignments 139
  - mouse, spare part numbers 26
- N**
- navigating in Computer Setup 93
  - network jack
    - location 16
    - pin assignments 140
  - next/fast forward button 8
  - num lock light 10
- O**
- operating system, product description 5
  - optical drive
    - location 15
    - precautions 32
    - product description 2
    - removal 52
    - spare part numbers 22, 25, 52
    - specifications 102
  - optical drive button 9
  - optical drive light 9, 15
- P**
- packing guidelines 34
  - password clearing 36
  - passwords 96
  - pin assignments
    - audio-in 138
    - audio-out 138
    - external monitor 139
    - headphone 138
    - microphone 138
    - monitor 139
    - network 140
    - RJ-45 140
    - Universal Serial Bus (USB) 141
  - plastic parts 31
  - Plastics Kit
    - contents 24
    - spare part number 20, 24, 29
  - play/pause button 8
  - pointing device
    - components 10
    - product description 5
  - ports
    - 1394 16
    - eSATA 16
    - expansion port 3 16
    - external monitor port 16
    - HDMI 16
    - monitor port 16
    - product description 3
    - Universal Serial Bus (USB) 15, 16
  - power button 7
  - power connector 14
  - power connector LED board
    - removal 70
    - spare part number 20, 30, 70
  - power cord set requirements 142
  - power cord, spare part numbers 26, 27
  - power light 7, 12
  - power requirements, product description 5
  - power-on password 96
  - previous/rewind button 8
  - processor
    - product description 1



- removal 85
- spare part numbers 21, 28, 30, 85
- processor fan
  - removal 75
  - spare part number 21, 29, 75
- processor heat sink
  - removal 83
  - spare part number 21, 29, 83
- product description
  - audio 2
  - camera 2
  - chipset 1
  - diskette drive 2
  - display panel 1
  - docking support 5
  - Ethernet 2
  - external media cards 3
  - graphics 1
  - hard drives 1
  - keyboard 5
  - memory module 1
  - modem 2
  - operating system 5
  - optical drives 2
  - pointing device 5
  - ports 3
  - power requirements 5
  - processors 1
  - product name 1
  - remote control 4
  - security 5
  - serviceability 5
  - TV tuner 3
  - wireless 2
- product name 1

## R

- rear components 13
- rear cover
  - removal 57
  - spare part number 20, 28, 57
- rear USB board
  - removal 71
  - spare part number 20, 30, 71
- recovery discs 132

- recovery, system 132, 137
- remote control
  - product description 4
  - spare part numbers 26, 29
- remote control button 8
- removal/replacement
  - preliminaries 31
  - procedures 37
- restore points 134
- restoring Computer Setup default settings 94
- RF coaxial cable jack jack 13
- RF input adapter cable, spare part number 26
- right-side components 15
- RJ-45 jack
  - location 16
  - pin assignments 140
- RTC battery
  - removal 81
  - spare part number 21, 30, 81
- Rubber Feet Kit, spare part number 21, 30, 39

## S

- S-Video-in jack 13
- Screw Kit
  - contents 108
  - spare part number 26, 29
- screw listing 108
- security cable slot 15
- Security menu 96
- security, product description 5
- selecting in Computer Setup 93
- serial number 18, 37
- service considerations 31
- serviceability, product description 5
- software
  - safeguarding information 132
- Speaker Kit, spare part number 23, 30
- speakers
  - illustrated 23
  - location 6
  - spare part number 23, 30, 44
- specifications
  - computer 98

- display 99, 100
- DVD±RW and CD-RW Combo Drive 102
- hard drive 101
- I/O addresses 105
- interrupts 104
- memory map 107
- optical drive 102
- system DMA 103
- static-shielding materials 35
- stop button 8
- subwoofer
  - location 17
  - removal 72
  - spare part number 21, 29, 72
- subwoofer analog channel output jack 14
- system board
  - removal 76
  - spare part number 20, 28, 76
- System Configuration menu 97
- system DMA 103
- system information 95
- system memory map 107
- system recovery 132
- system restore points 134

## T

- theater mode button 8
- Thermal Material Kit, spare part number 27
- thermal material, replacement 84, 88
- tools required 31
- top components 6
- top cover
  - removal 59
  - spare part number 20, 29, 59
- TouchPad components
  - left button 10
  - light 10
  - on/off button 10
  - right button 10
  - scroll zone 10
  - TouchPad 10

- TouchPad on/off board
  - removal 62
  - spare part number 20, 29, 62
- transporting guidelines 34
- treble light 10
- treble or bass volume down light 9
- treble or bass volume scroll zone 9
- treble or bass volume up light 9
- treble/bass button 10
- TV audio line-in jack 13
- TV play button 8
- TV tuner
  - product description 3
  - spare part number 26
- TV tuner antenna, spare part number 26
- TV tuner module
  - removal 49
  - spare part numbers 22, 29, 49
- TV tuner module compartment 17
- TV tuner module compartment cover
  - illustrated 24
  - removal 49

## U

- Universal Serial Bus (USB) port
  - locations 15, 16
  - pin assignments 141
- unknown password 36
- USB board
  - removal 71
  - spare part numbers 20, 21, 30, 69, 71
- USB digital drive, spare part number 26

## V

- vents 13, 14, 17
- video board
  - removal 90
  - spare part number 21, 30, 90
- video board fan
  - removal 89
  - spare part number 21, 29, 89

- video board heat sink
  - removal 87
  - spare part number 21, 29, 87
- video connector board
  - removal 73
  - spare part number 20, 30, 73
- volume down light 9
- volume mute button 9
- volume mute light 9
- volume scroll zone 9
- volume up light 9

## W

- Windows application key 11
- Windows logo key 11
- wireless button 9
- wireless light 9
- wireless, product description 2
- WLAN module
  - removal 47
  - spare part numbers 21, 27, 29, 47
- WLAN module compartment cover
  - illustrated 24
  - removal 48
- workstation guidelines 34

